

REFERENCE ONLY

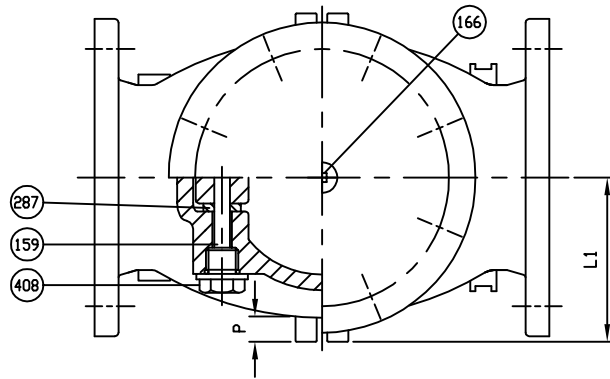

MARKING  
SIZE (INCH)  
200 CWP  
AWWA C508

⊕  
SCI  
YEAR  
POURING DATE

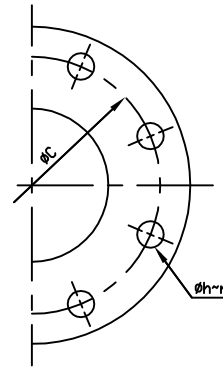
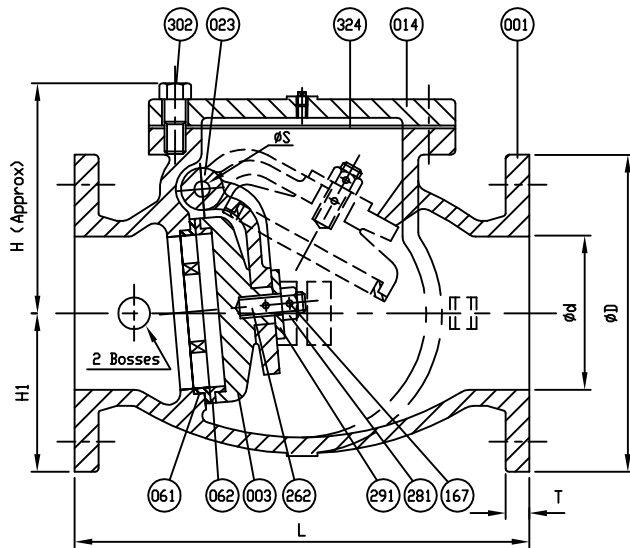

408	Plug B	Brass	B 21	1
324	Gasket	Rubber (Buna N)	D 2000 BK 807	1
302	Cover Bolt	Zinc Coated Steel	A 307 Grade B	1 set
291	Washer	Brass	B 21	1
287	Spacer	Brass	B 21	2
281	Disc Nut	Brass	B 21	1
262	Disc Stud	Brass	B 21	1
167	Pin	Stainless Steel	A 276 Type 304	2
166	Plug A	Stainless Steel	A 276 Type 304	1
159	Hinge Pin	Stainless Steel	A 276 Type 304	1
062	Disc Seat Ring	Bronze	B 62	1
061	Body Seat Ring	Bronze	B 62	1
023	Arm	Ductile Iron	A 536 Gr. 65-45-12	1
014	Cover	Cast Iron	A 126 Class B	1
003	Disc	Cast Iron	A 126 Class B	1
001	Body	Cast Iron	A 126 Class B	1
ND.	PARTS	MATERIAL	ASTM. DESIGNATION.	Q'TY

MATERIAL LIST

HYDRO SHELL	400	PSI.
HYDRO VALVE SEAT	200	PSI.
HYDRO BACK SEAT	—	PSI.
AIR SEAT	—	PSI.
STEAM	—	PSI.

TEST PRESSURE

WORKING PRESSURE	200	PSI.
------------------	-----	------

MUELLER

500 WEST ELDERADO ST. P.O. BOX 671 DECATUR, IL 62525 PHONE: 217-423-4471

SCALE	DR. JON COLPAN	DATE 02/04/11	REF. DWG.
N.T.S.	CHK.	APP.	E.C.N. USA1846A

TITLE  
SIZE 2" TO 12" GRAVITY SWING CHECK VALVE AWWA C508  
BRONZE BODY SEAT RING & BRONZE DISC SEAT RING

TYPE: A2600-6BB	DWG NO. M80019	REV. 1
-----------------	----------------	--------

SIZE in. mm.	L	ANSI B16.1 CL. 125					ØS	H	H1	L1	PLUG SIZE
		ØD	ØC	Øh	n	T					
2 (50)	8	6	4 3/4	3/4	4	5/8	3/8	4 15/16	3	2 13/16	1/2
2 1/2 (65)	8 1/2	7	5 1/2	3/4	4	11/16	3/8	5 11/16	3 1/2	3 9/16	1/2
3 (80)	9 1/2	7 1/2	6	3/4	4	3/4	1/2	6 1/16	3 3/4	4 1/16	1/2
4 (100)	11 1/2	9	7 1/2	3/4	8	15/16	1/2	6 7/8	4 1/2	4 15/16	1/2
6 (150)	14	11	9 1/2	7/8	8	1	3/4	8 1/2	5 1/2	5 15/16	3/4
8 (200)	19 1/2	13 1/2	11 3/4	7/8	8	1 1/8	7/8	9 15/16	6 3/4	8 1/16	3/4
10 (250)	24 1/2	16	14 1/4	1	12	1 3/16	1	11 3/16	8	9 3/16	1
12 (300)	27 1/2	19	17	1	12	1 1/4	1 1/8	13 9/16	9 1/2	10 13/16	1

DS01 ISSUED - 240640 REVISED -