

METER SIZE	1-1/2"	2"
A (MINIMUM)	12"	12"
B	13.25"	17.25"
CLOSED NIPPLE	047139	047139
RISER TEE	509704	530146
BY-PASS SUB ASSEMBLY	283236E	682158E
INLINE BALL VALVE	330B25170N	330B25170N
FULL PORT BALL VALVE	500B242860IN	550B242860IN

ITEM NO	PART NUMBER	QTY	DESCRIPTION
1		1	CLOSED NIPPLE
2		2	RISER TEE (FIP X SOLDER X FIP)
3		2	RISER SUB ASSEMBLY
4		1	BY-PASS SUB ASSEMBLY
5	B25170N	1	INLINE BALL VALVE (110 X FIP)
6	B242860IN	2	FULL PORT BALL VALVE

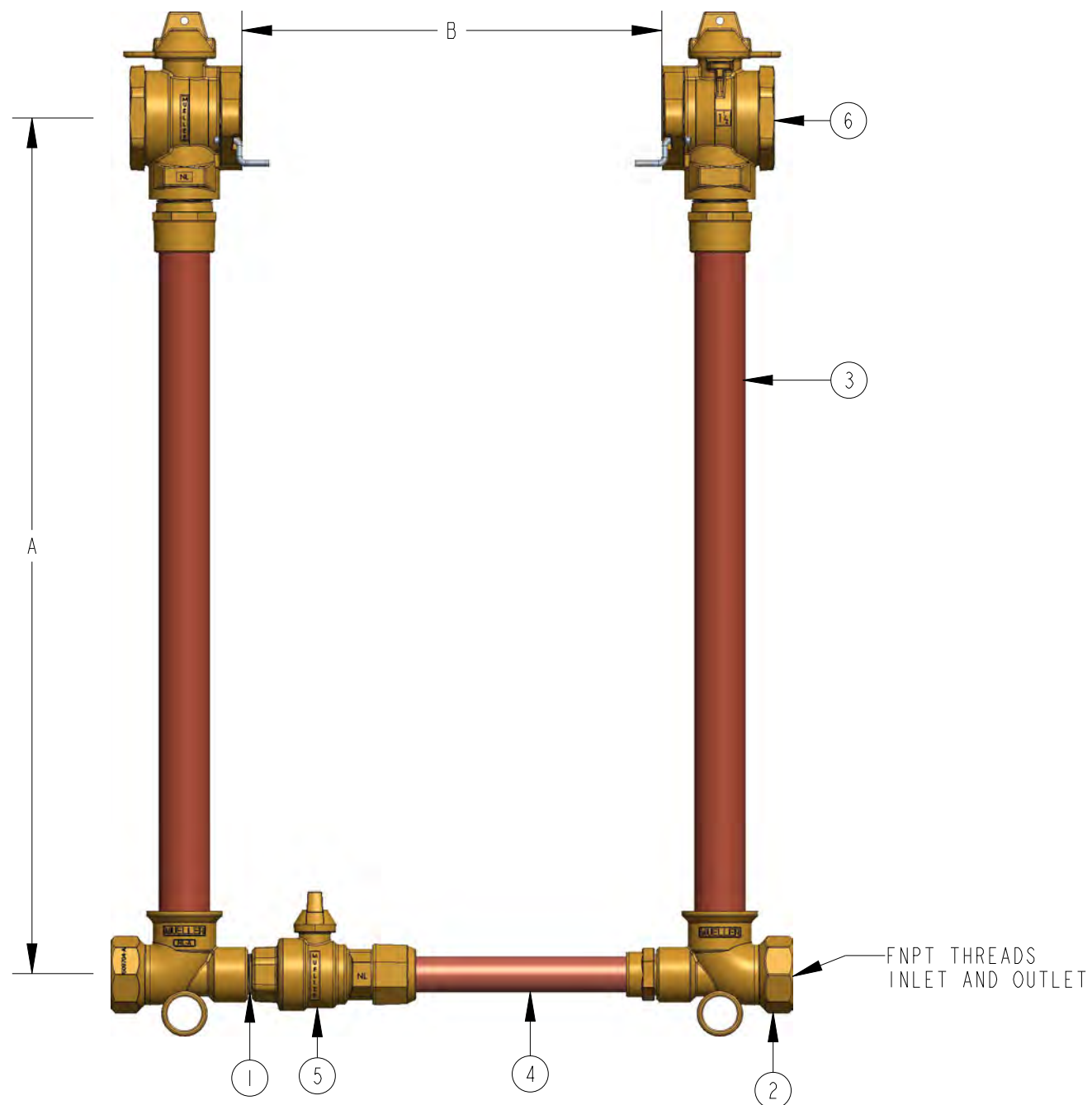

096B2423-----N

DR. BY	AOD	10/14/22	UNLESS OTHERWISE NOTED		THIRD ANGLE PROJECTION		C.B. NO.
CHKR			BREAK CAST CORNER(S)---				
ENGR			BREAK MACH CORNER(S)---		PURCH.	FINISH	PATT. NO.
MGR			TOLERANCES UNLESS OTHERWISE NOTED		REF. NO.	SCALE	
MFG			LINEAR	ANGULAR	NONE		
TOOL			±	±	STK. NO.		
FDRY							
MAT'L:							
MUELLER			DESCR. COPPER METER SETTER LOW LEAD BRASS			NUMBER 096B2423-----N	