

METER SIZE	5/8"	5/8"X3/4"	3/4"	1"
A (MINIMUM)	9"	9"	10"	12"
B	7-7/8"	7-7/8"	9-5/16"	11-1/8"
TIE BAR (IF NECESSARY; SEE NOTE)	037022	532044	507859	074963
FULL PORT BALL VALVE	203B24265N	215B24265N	215B24265N	330B24265N
VERTICAL ASSE APPROVED CHECK VALVE	203HI4460AN	215HI4460AN	215HI4460AN	330HI4460AN
METER BAR	532075E	532075E	507858E	532220E

ITEM NO	PART NUMBER	QTY	DESCRIPTION
1		1	TIE BAR (SEE NOTE)
2	B24265N	1	FULL PORT BALL VALVE
3	HI4460AN	1	VERTICAL ASSE APPROVED CHECK VALVE
4		1	METER BAR
5		1	RISER SUB ASSEMBLY
6		1	RISER SUB ASSEMBLY

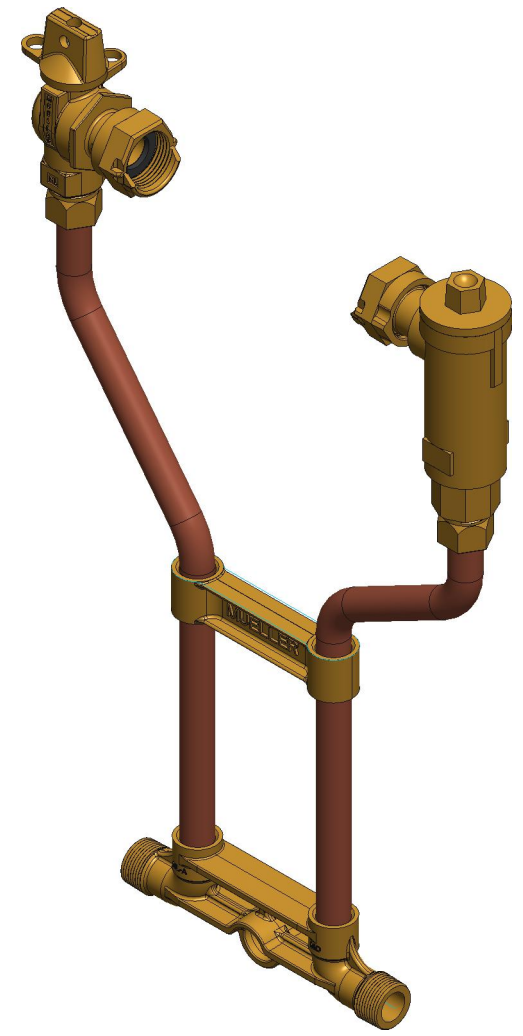
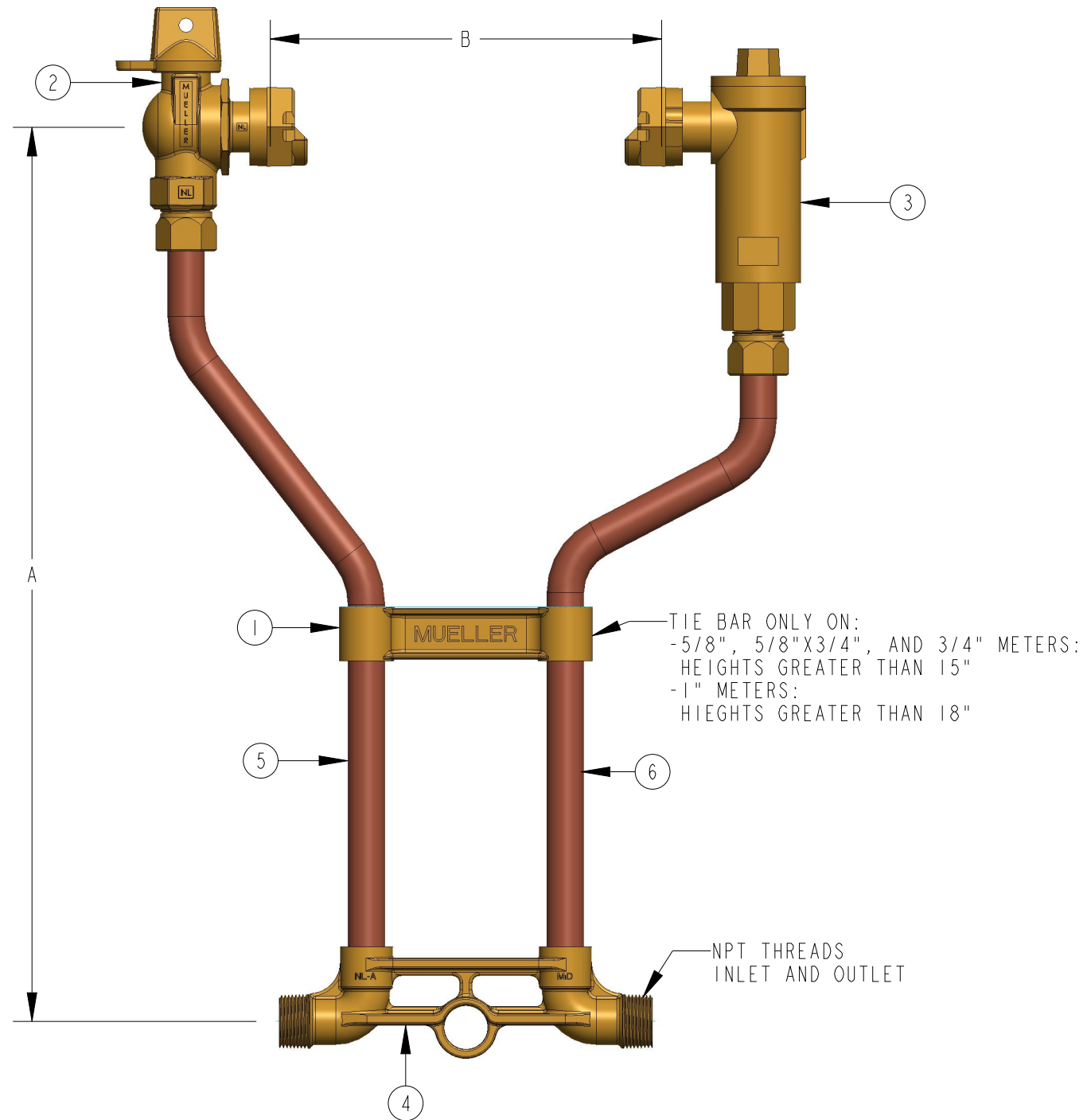

B2434--6A--N

DR. BY	AOD	4/28/22	UNLESS OTHERWISE NOTED		THIRD ANGLE PROJECTION		C.B. NO.
CHKR			BREAK CAST CORNER(S)---				
ENGR			BREAK MACH CORNER(S)---		PURCH.	FINISH	PATT. NO.
MGR			TOLERANCES		REF. NO.	SCALE	
MFG			UNLESS OTHERWISE NOTED			NONE	
TOOL			LINEAR	ANGULAR	STK. NO.		
FDRY			±	±			
MAT'L:							
			DESCR. COPPER METER SETTER LOW LEAD BRASS			NUMBER B2434--6A--N	