

No.	DESCRIPTION	MATERIAL
1	STEM	LEAD FREE BRASS ALLOY ASTM B584/B371
2	O-RING	EPDM D2000
3	BALL	LEAD FREE BRASS ALLOY ASTM B584
4	GASKET - SEAL	EPDM D2000
5	BODY	LEAD FREE BRASS ALLOY ASTM B584
6	END PIECE	LEAD FREE BRASS ALLOY ASTM B584
7	O-RING	EPDM D2000
8	CAP	CAST BRASS ALLOY ASTM B584
9	SCREW	18-8 STAINLESS STEEL
10	SADDLE NUT	CAST BRASS ALLOY ASTM B584
11	SNAP RING	COPPER ALLOY CDA521
12	RUBBER GASKET	NITRILE D2000

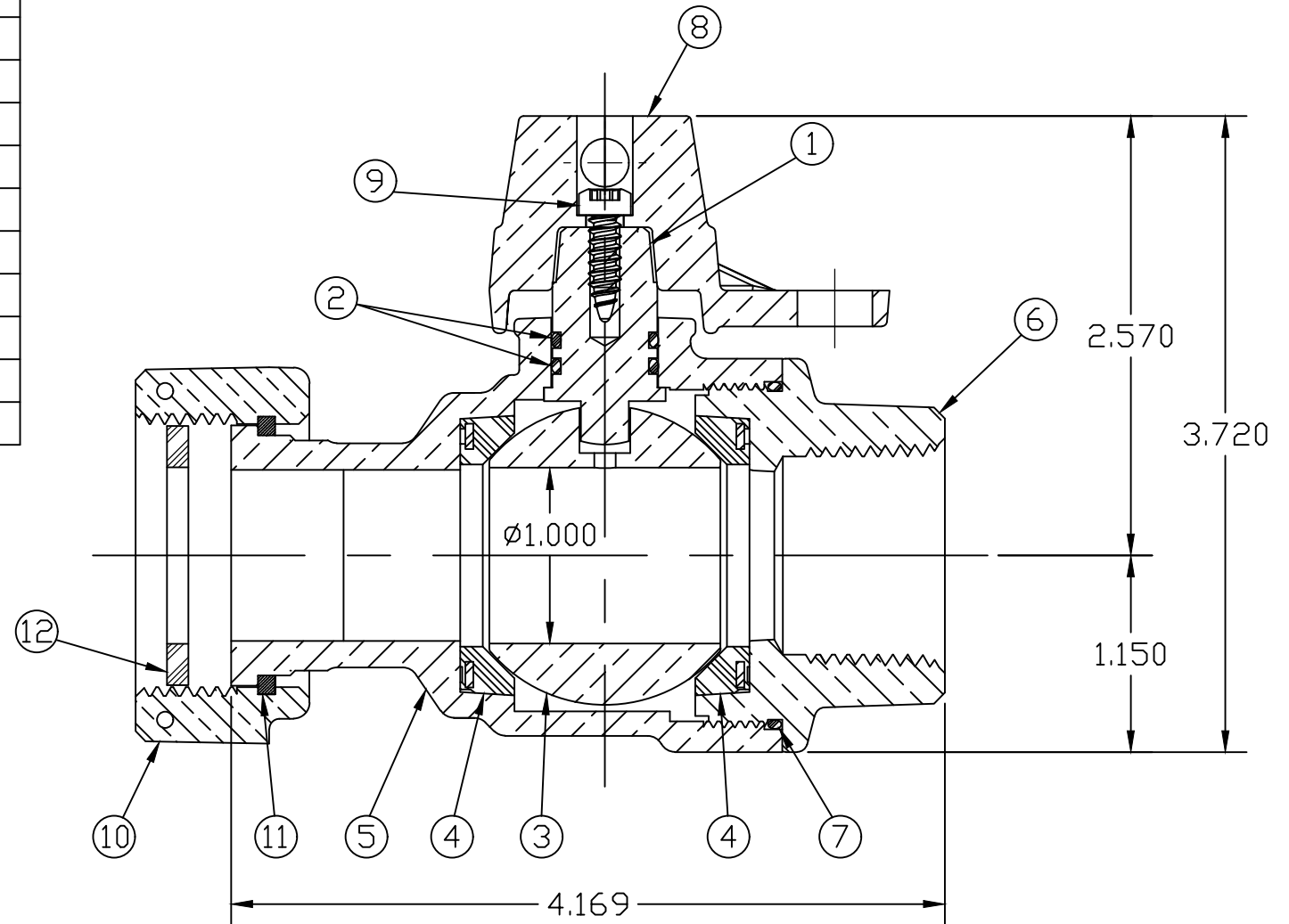

MEETS ALL REQUIREMENTS OF AWWA C800
 ALL STEMS ARE LEAD FREE BRASS ALLOY C89833/C69300
 ALL WETTED PARTS ARE LEAD FREE BRASS ALLOY C89833/C87850
 ALL NON WETTED PARTS ARE BRASS ALLOY C83600/C87850

DRFTR	AD	03/13/23	MUELLER	
CHKR				
ENGR			UNLESS OTHERWISE NOTED SURFACE PREPARATION: BREAK CORNER(S) ---- .000 SURFACE FINISH -- XX RMS	THIRD ANGLE PROJECTION
MGR				TOLERANCE(S): LINEAR ----- ± .000 ANGULAR ----- ± 0°00'
STK No:				
MAT'L:				
DESCR.			DWG NUMBER	
1" INLINE BALL METER VALVE LOCK OPEN/CLOSE (PLAIN NUT MTR x FIP)			B24351081N	

TITLE TO AND OWNERSHIP OF THIS ENGINEERING DATA REMAINS IN Mueller Co. NO USE IS TO BE MADE OF THIS DATA EXCEPT AS SPECIFICALLY AUTHORIZED BY Mueller Co. ASSENT ON THE PART OF THE RECIPIENT TO THESE CONDITIONS IS PRESUMED

DWG NUMBER
B24351081N