

SIZE	A	B	C	D	E
3/4" R	.625	3.544	.875	2.611	3.486

ITEM	DESCRIPTION	MATERIAL DESCRIPTION
1	BODY	CAST NO LEAD BRASS ALLOY
2	CAP	CAST BRASS ASTM B62 ALLOY C83600
3	STEM	NO LEAD BRASS ALLOY
4	BALL	NO LEAD BRASS ALLOY
5	GASKET	EPDM D2000
6	SCREW	AISI 302 STAINLESS STEEL
7	O-RING	EPDM D2000
8	O-RING	EPDM D2000
9	END PIECE	CAST NO LEAD BRASS ALLOY
10	SNAP RING	COPPER ALLOY WIRE CDA 521
11	PLAIN NUT	CAST BRASS ASTM B62 ALLOY C83600
12	RUBBER GSKT	ASTM D2000 (SBR)
13	HANDLE	CAST BRASS ASTM B62 ALLOY C83600
14	MACHINE SCREW	AISI 304 STAINLESS STEEL
15	HEX LOCKNUT	AISI 18-8 STAINLESS STEEL

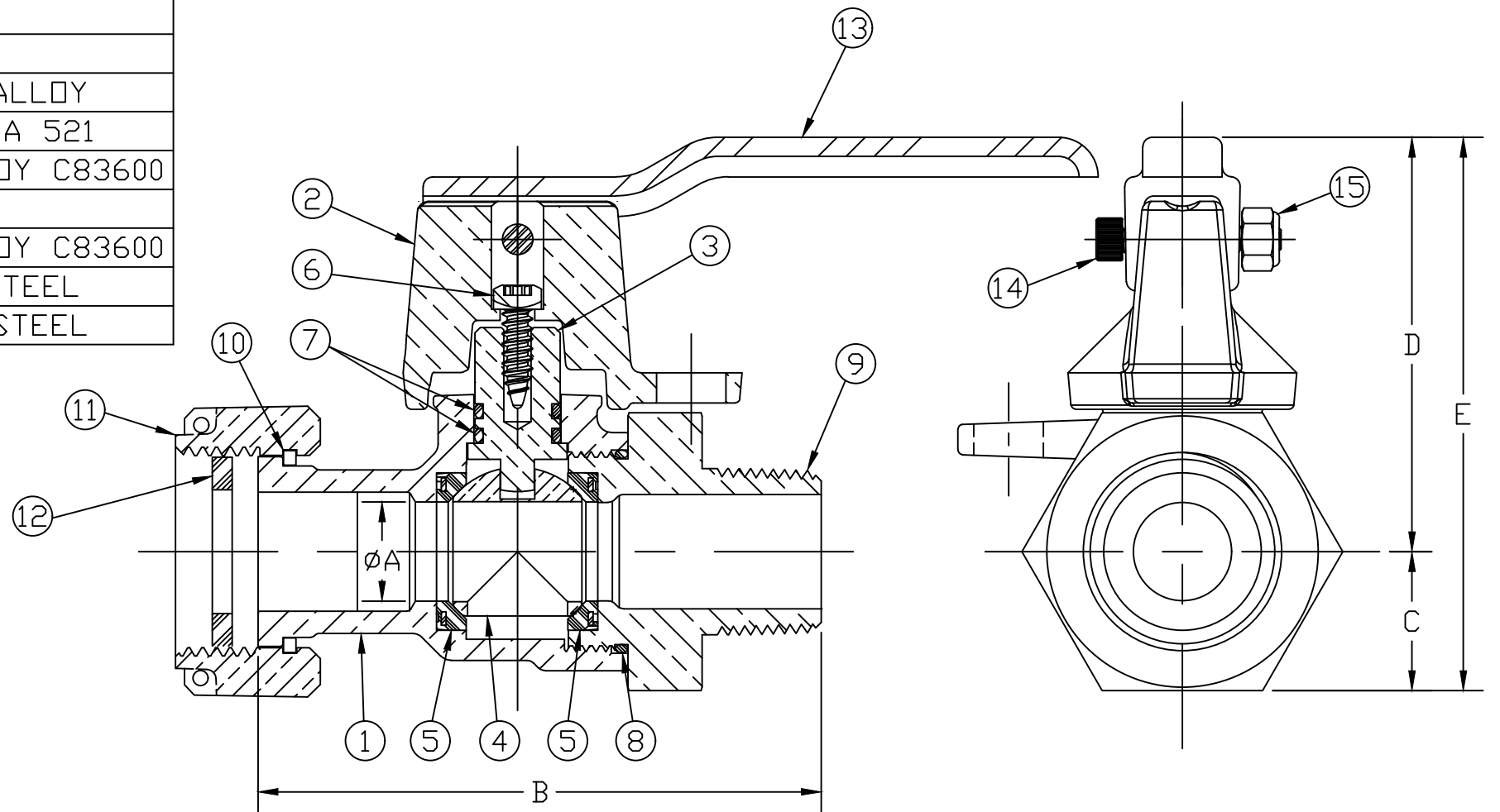

ALL WETTED PARTS ARE NO LEAD BRASS ALLOY

FILEPATH: PROD-ENG\MUELLER\ASYSUBMITTALS\B24394411RN

DWG NUMBER
B24394411RN

TITLE TO AND OWNERSHIP OF THIS ENGINEERING DATA REMAINS IN Mueller Co. NO USE IS TO BE MADE OF THIS DATA EXCEPT AS SPECIFICALLY AUTHORIZED BY Mueller Co. ASSENT ON THE PART OF THE RECIPIENT TO THESE CONDITIONS IS PRESUMED

DRFTR	RWB	12/15/21	MUELLER	UNLESS OTHERWISE NOTED THIRD ANGLE PROJECTION SURFACE PREPARATION: BREAK CORNER(S) ---- .000 SURFACE FINISH -- XX RMS TOLERANCE(S): LINEAR ----- ± .000 ANGULAR ----- ± 0°00'	
CHKR					
ENGR					
MGR					
	BY	DATE	REF. No.	SCALE	
				NONE	
	STK No:		DESCR. INLINE REDUCED BALL NLB METER VALVE/ HANDLE (PLAIN MTR x MIP)		
	MAT'L:		DWG NUMBER B24394411RN		
REV	ECR	DESCRIPTION	DATE	BY	CHKR
PER EST NO: DXXXX EST FIN WT = 0.0000 lbs					