

| No. | DESCRIPTION | MATERIAL DESCRIPTION |
|-----|----------------|-------------------------------------|
| 1 | BODY | CAST NO LEAD BRASS ALLOY |
| 2 | CAP | CAST BRASS ASTM B62 ALLOY C83600 |
| 3 | STEM | NO LEAD BRASS ALLOY |
| 4 | BALL | NO LEAD BRASS ALLOY |
| 5 | GASKET | ASTM D2000 EPDM |
| 6 | SCREW | 18-8 STAINLESS STEEL |
| 7 | O-RING | ASTM D2000 EPDM |
| 8 | END PIECE | CAST NO LEAD BRASS ALLOY |
| 9 | O-RING | ASTM D2000 EPDM |
| 10 | CTS GASKET SUB | ASTM D2000(SBR)&410 STAINLESS STEEL |
| 11 | CONN NUT | CAST BRASS ASTM B62 ALLOY C83600 |

| SIZE | ØA | B | C | D | E |
|-----------|------|------|------|------|------|
| 3/4"R | .63 | 3.44 | .75 | 2.12 | 2.87 |
| 3/4" | .75 | 3.59 | .85 | 2.26 | 3.11 |
| 1"R | .75 | 4.00 | .84 | 2.12 | 2.96 |
| 1" | 1.00 | 5.03 | 1.15 | 2.55 | 3.70 |
| 1" x 3/4" | .75 | 3.78 | .84 | 2.32 | 3.16 |

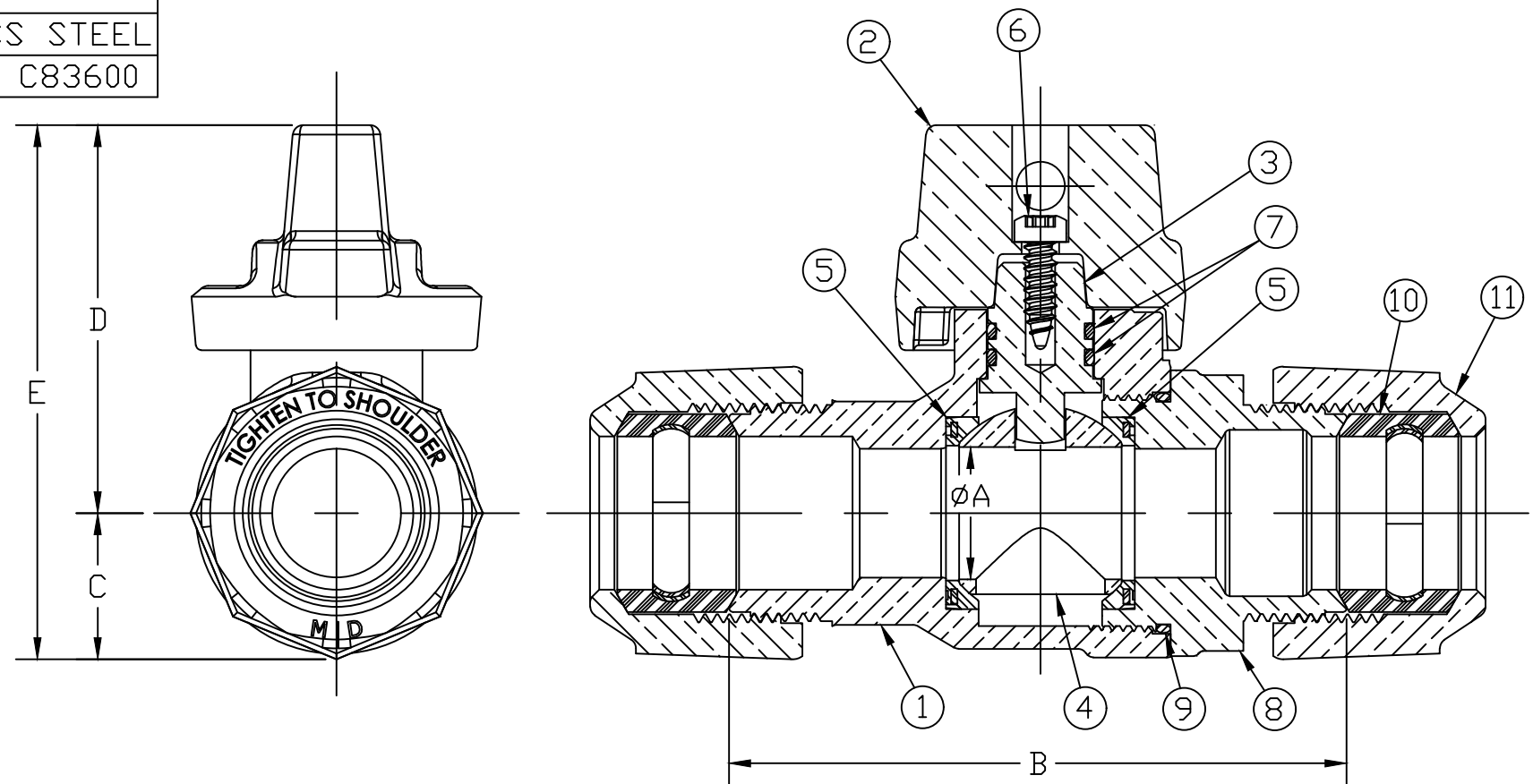

ALL WETTED PARTS ARE NO LEAD BRASS ALLOY

DWG NUMBER
B25209N

TITLE TO AND OWNERSHIP OF THIS ENGINEERING DATA REMAINS IN Mueller Co. NO USE IS TO BE MADE OF THIS DATA EXCEPT AS SPECIFICALLY AUTHORIZED BY Mueller Co. ASSENT ON THE PART OF THE RECIPIENT TO THESE CONDITIONS IS PRESUMED

| | | | | | | | | | | | | |
|--|--|--|--|--|--|-------|-----|---------|-------------------|--|----------|-----------------------|
| | | | | | | DRFTR | RWB | 4/23/21 | MUELLER | UNLESS OTHERWISE NOTED THIRD ANGLE PROJECTION SURFACE PREPARATION: BREAK CORNER(S) ---- .000 SURFACE FINISH --XXX RMS TOLERANCE(S): LINEAR ----- ± .000 ANGULAR ----- ± 0°00' | REF. No. | SCALE FULL |
| | | | | | | CHKR | | | | | | |
| | | | | | | ENGR | | | | | | |
| | | | | | | MGR | | | | | | |
| | | | | | | | BY | DATE | STK No: | | | |
| | | | | | | | | | MAT'L: | | | |
| | | | | | | | | | DESCR. | INLINE NLB BALL CURB VALVE (110CTS x 110CTS) | | DWG NUMBER B25209N |
| | | | | | | | | | PER EST NO: DXXXX | EST FIN WT = 0.0000 lbs | | |