

DR2A

MUELLER CONFIDENTIAL
 TITLE TO AND OWNERSHIP OF THIS ENGINEERING DATA REMAINS IN MUELLER CO. NO USE IS TO BE MADE OF THIS DATA EXCEPT AS SPECIFICALLY AUTHORIZED BY MUELLER CO. ASSENT ON THE PART OF RECIPIENTS TO THESE CONDITIONS IS PRESUMED.

PIPE O.D. RANGE		KIND AND SIZE OF PIPE	DOUBLE ALLOY STEEL STRAPS ^(A) WITH AWWA I.P. THREAD (F.I.P.T.)						DOUBLE ALLOY STEEL STRAPS ^(A) WITH AWWA TAPER THREAD (C.C.)										
INCH	MM		A-C	STD. STEEL IPS PVC	CAST IRON, DUCTILE IRON, PVC C900	BASE CATALOG NUMBER	SIZE OF TAPPING (ADD TO "BASE" TO COMPLETE CATALOG NUMBER)						BASE CATALOG NUMBER	SIZE OF TAPPING (ADD TO "BASE" TO COMPLETE CATALOG NUMBER)					
							1/2"	3/4"	1"	1-1/4"	1-1/2"	2"		1/2"	3/4"	1"	1-1/4"	1-1/2"	2"
2.35-2.50	59.7-63.5	2"	2"*	DR 2 A 0235 IP	050	075	100	-	-	-	DR 2 A 0235 CC	050	075	100	-	-	-		
3.56-4.00	91.0-101.0	3-1/2"	3"	DR 2 A 0356 IP	050	075	100	-	-	-	DR 2 A 0356 CC	050	075	100	-	-	-		
4.47-5.32	113.5-135.1	4"	4"	DR 2 A 0447 IP	050	075	100	125	150	200	DR 2 A 0447 CC	050	075	100	125	150	200		
6.59-7.37	167.4-187.2	6"	6"	DR 2 A 0659 IP	050	075	100	125	150	200	DR 2 A 0659 CC	050	075	100	125	150	200		
8.54-9.79	216.9-248.7	8"	8"	DR 2 A 0854 IP	050	075	100	125	150	200	DR 2 A 0854 CC	050	075	100	125	150	200		
10.64-12.12	270.3-307.8	10"	10"	DR 2 A 1064 IP	050	075	100	125	150	200	DR 2 A 1064 CC	050	075	100	125	150	200		
12.62-14.38	320.5-365.3	12"	12"	DR 2 A 1262 IP	050	075	100	125	150	200	DR 2 A 1262 CC	050	075	100	125	150	200		
17.40-18.80	442.0-477.5	-	16"	DR 2 A 1740 IP	-	075	100	125	150	200	DR 2 A 1740 CC	-	075	100	125	150	200		

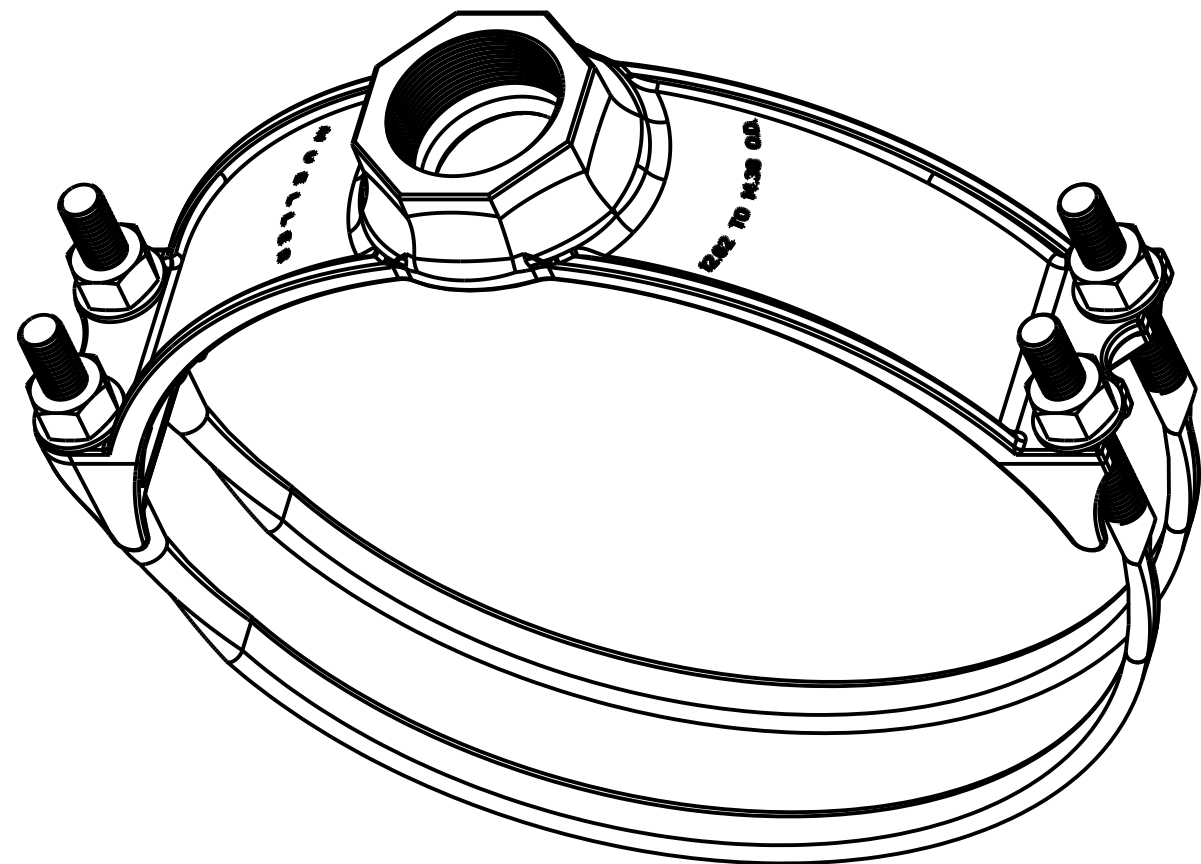

* IMPORTANT - CAREFULLY CHECK THE RANGE OF THE SADDLE WITH THE O.D. OF THE PIPE BEING USED.
 ** THE OUTSIDE DIAMETER OF A-C PIPE VARIES FROM MANUFACTURER TO MANUFACTURER. TO MAKE CERTAIN YOU SELECT THE PROPER CLAMP:
 1) DETERMINE THE O.D. OF THE PIPE AT THE POINT OF SADDLE INSTALLATION;
 2) FROM THE PIPE O.D. RANGE COLUMN OF THE ABOVE CHART, CHOOSE A SADDLE THAT HAS A PIPE O.D. RANGE THAT INCLUDES THE DETERMINED PIPE DIAMETER.

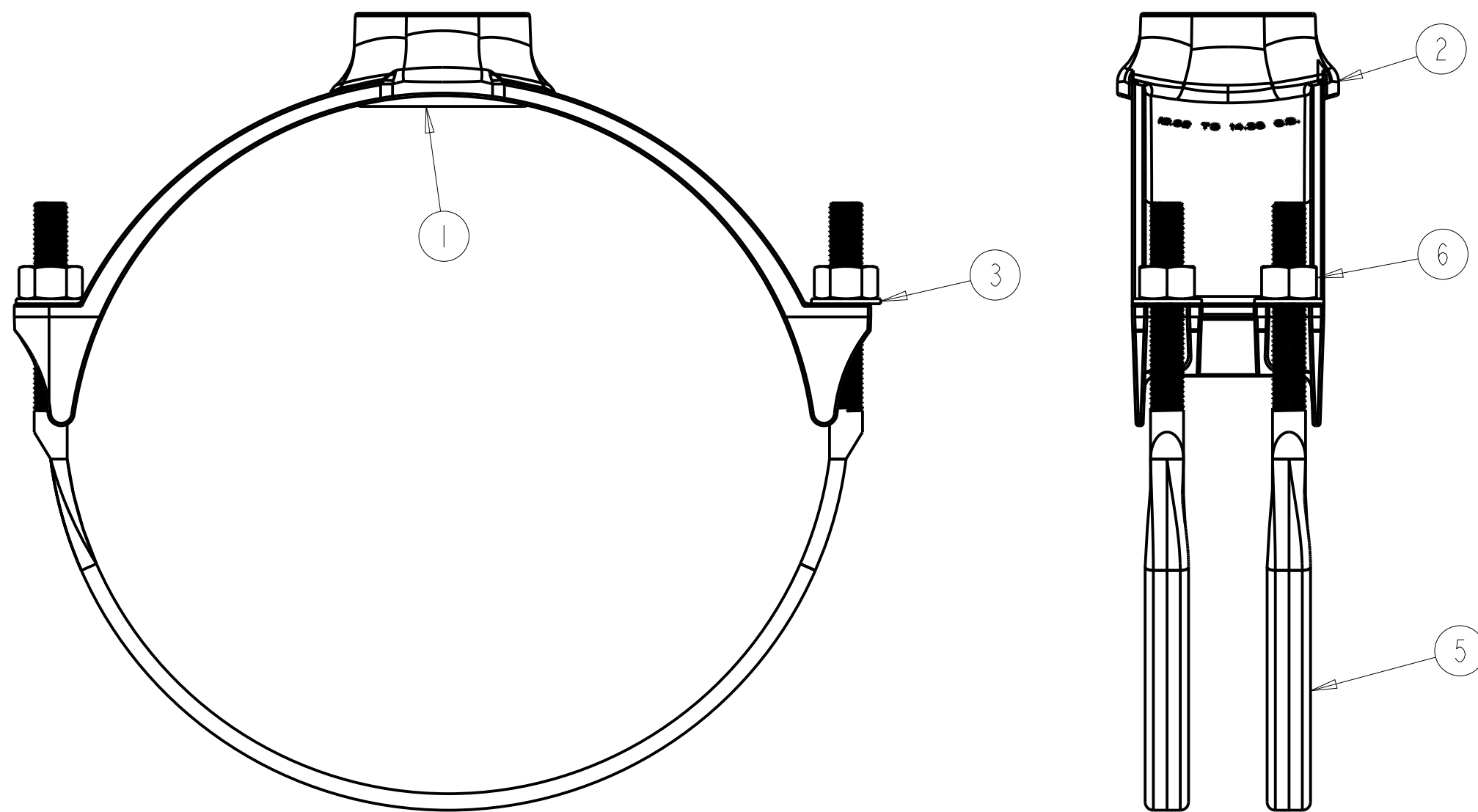

PARTS LIST				
ITEM	DESCRIPTION	MATERIAL	ASTM	TYPE
1	O - RING	RUBBER	D2000	***
2	SADDLE	DUCTILE IRON	A536	60-40-18
3	WASHER	ZINC PLATED STEEL	F844	
5	STRAP	ZINC PLATED STEEL	AISI 1008	
6	5/8" HEAVY HEX NUT	ZINC PLATED STEEL	A563	GRADE A

*** MUELLER RUBBER CODE R91

DR2A SERIES DUCTILE IRON SERVICE SADDLES - DOUBLE STRAP

ECO1700105
 TBE 05/29/18
 RELEASE

ECN2003441 - REVISION ^(A)
 ETB 04/05/2021
 UPDATED CATALOG TITLES TO STATE
 "ALLOY" ILO "STAINLESS"

DR. BY	TBE	05/29/18	UNLESS OTHERWISE NOTED	THIRD ANGLE PROJECTION	C.B. NO.
CHKR			BREAK CAST CORNER(S)---		
ENGR			BREAK MACH CORNER(S)---	PURCH.	PATT. NO.
MGR			TOLERANCES	FINISH	
MFG			UNLESS OTHERWISE NOTED	REF. NO.	SCALE
TOOL			LINEAR		NONE
FDRY			±	STR. NO.	
MAT'L: NOTED					
MUELLER				DESCR.	NUMBER
				DR2A SERIES DUCTILE IRON SERVICE SADDLES - DOUBLE STRAP	DR2A