

No.	DESCRIPTION	MATERIAL
1	SPUD	CAST LOW LEAD BRASS ALLOY
2	PJ CPLG NUT	CAST BRASS ASTM B62 ALLOY C83600
3	PJ GASKET	ASTM D2000 NITRILE
4	PJ WASHER	POLYPROPYLENE
5	GASKET	ASTM D2000 NITRILE
6	WASHER	POLYPROPYLENE
7	COUPLING NUT	CAST BRASS ASTM B62 ALLOY C83600

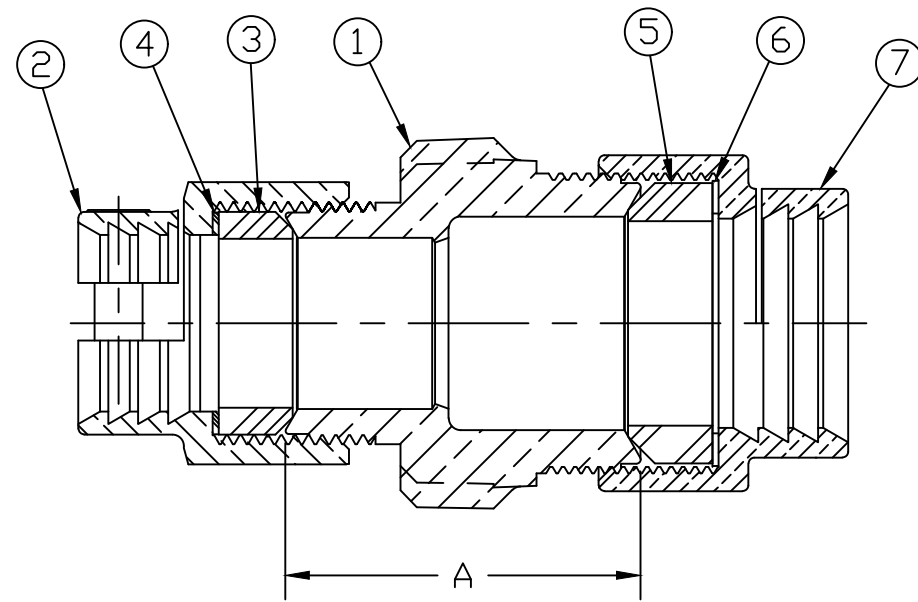

SIZE	A
3/4"	1.85
1"	2.15

ALL WETTED PARTS ARE LOW LEAD BRASS ALLOY

FILEPATH: PROD-ENG\MUELLER\SUBMITTALS\E15443N

DWG NUMBER
E15443N
JJ-MRKING

TITLE TO AND OWNERSHIP OF THIS ENGINEERING DATA REMAINS IN Mueller Co. NO USE IS TO BE MADE OF THIS DATA EXCEPT AS SPECIFICALLY AUTHORIZED BY Mueller Co. ASSENT ON THE PART OF THE RECIPIENT TO THESE CONDITIONS IS PRESUMED

						DRFTR	RWB	4/3/18	Mueller Co.		
						CHKR					
						ENGR					
						MGR					
									UNLESS OTHERWISE NOTED	THIRD ANGLE PROJECTION	
									SURFACE PREPARATION:		
									BREAK CORNER(S) ---- .000		
									SURFACE FINISH -- 000 RMS	REF. No.	SCALE
									TOLERANCE(S):		NONE
									LINEAR ----- ± .000		
									ANGULAR ----- ± 0°00'		
								STK No:			
								MAT'L:			
								DESCR.	STRAIGHT LLB SERVICE FITTING (CTS PJ x IPS PJ)	DWG NUMBER E15443N	
								PER EST NO: DXXXX EST FIN WT = 0.0000 lbs			