

No.	DESCRIPTION	MATERIAL
1	SPUD	CAST LOW LEAD BRASS ALLOY
2	COMP GSKT	NITRILE ASTM D2000
3	WASHER	POLYPROPYLENE
4	CPLG NUT	CAST BRASS ASTM B62 ALLOY C83600

SIZE	A	B
3/4"	2.000	2.000
1"	2.000	2.000

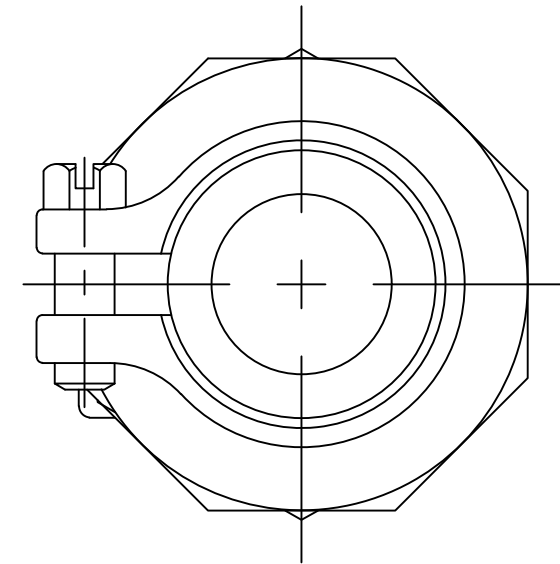
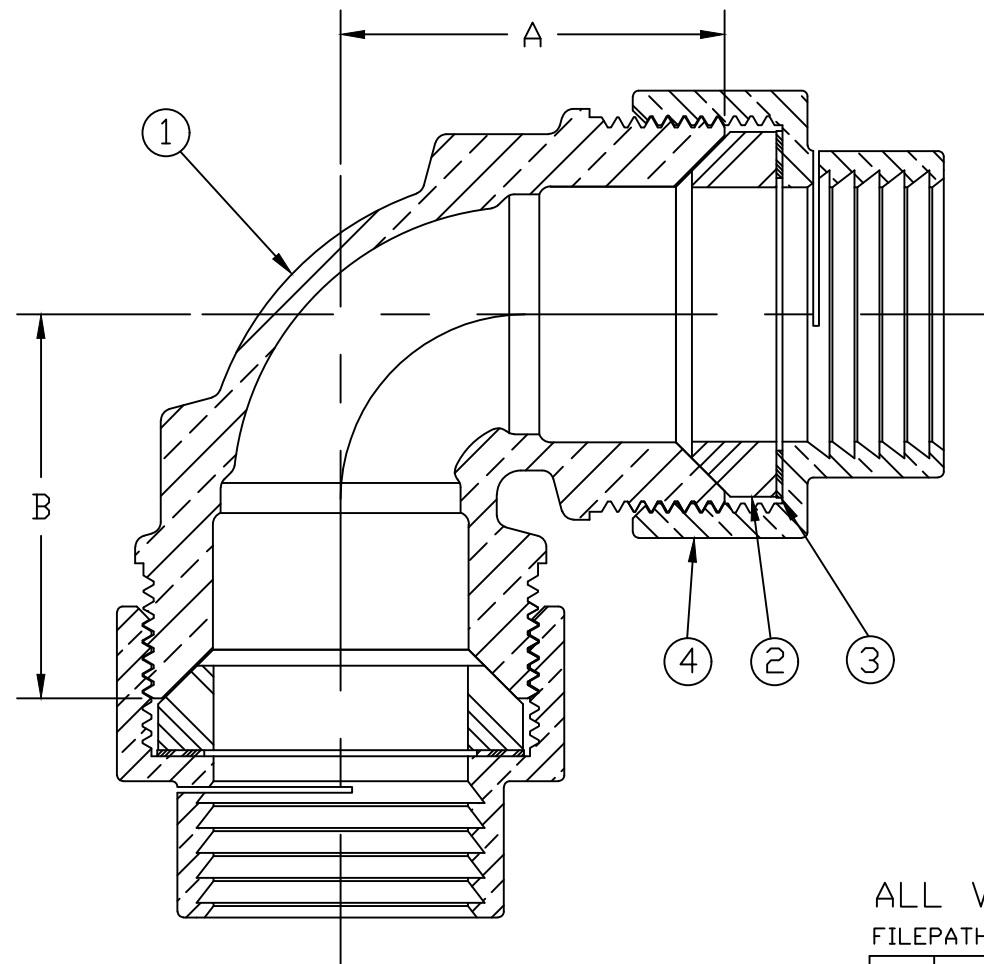

ALL WETTED PARTS ARE LOW LEAD BRASS ALLOY

FILEPATH: PROD-ENG\MUELLER\ASYSUBMITTALS\E15547N

						DRFTR	RWB	4/3/18	<b>MUELLER</b>	UNLESS OTHERWISE NOTED THIRD ANGLE PROJECTION SURFACE PREPARATION: BREAK CORNER(S) ---- .000 SURFACE FINISH -- XX RMS TOLERANCE(S): LINEAR ----- ± .000 ANGULAR ----- ± 0°00'	REF. No.	SCALE NONE
						CHKR						
						ENGR						
						MGR						
							BY	DATE	STK No:			
									MAT'L:			
									DESCR.	90° ELL LLB SERVICE FITTING (IPS PE PJ x IPS PE PJ)		DWG NUMBER E15547N
									PER EST NO: DXXXX EST FIN WT = 0.0000 lbs			

DWG NUMBER  
E15547N  
JJ-MRKTNG

TITLE TO AND OWNERSHIP OF THIS ENGINEERING  
DATA REMAINS IN Mueller Co. NO USE IS TO BE  
MADE OF THIS DATA EXCEPT AS SPECIFICALLY  
AUTHORIZED BY Mueller Co. ASSENT ON THE PART  
OF THE RECIPIENT TO THESE CONDITIONS IS PRESUMED