

No.	QTY.	DESCRIPTION	MATERIAL
1	1	STEM	LEAD FREE BRASS ALLOY ASTM B584/B371
2	2	O-RING	EPDM D2000
3	1	BALL	LEAD FREE BRASS ALLOY ASTM B584
4	1	RUBBER GASKET	EPDM D2000
5	1	BODY	LEAD FREE BRASS ALLOY ASTM B584
6	1	O-RING	EPDM D2000
7	1	END PIECE	LEAD FREE BRASS ALLOY ASTM B584
8	1	COMP GASKET	RUBBER CODE R93
9	1	WASHER	POLYPROPYLENE
10	1	COUPLING NUT	CAST BRASS ALLOY ASTM B584
11	1	CAP SCREW	304 STAINLESS STEEL

SIZE	ØA	B	C	D
3/4"	.75	3.83	1.39	.89
1"	1.00	4.37	1.59	1.15
1-1/2"	1.50	5.50	2.24	1.50
2"	2.00	6.57	2.27	1.82

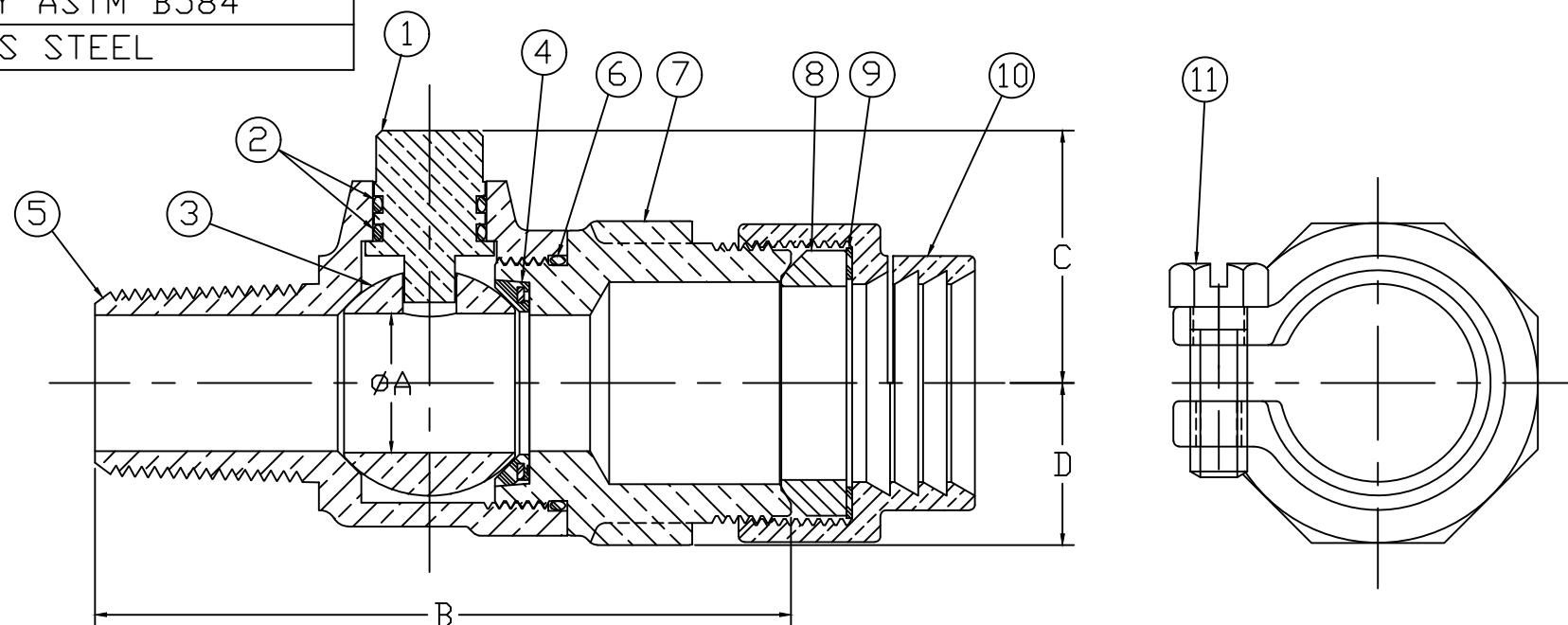

MEETS ALL REQUIREMENTS OF AWWA C800
 ALL STEMS ARE LEAD FREE BRASS ALLOY C89833/C69300
 ALL WETTED PARTS ARE LEAD FREE BRASS ALLOY C89833/C87850
 ALL NON WETTED PARTS ARE BRASS ALLOY C83600/C87850

DRFTR	AD	03/08/23	MUELLER	
CHKR				
ENGR			UNLESS OTHERWISE NOTED SURFACE PREPARATION: BREAK CORNER(S) ---- .000 SURFACE FINISH -- XX RMS	THIRD ANGLE PROJECTION
MGR				TOLERANCE(S): LINEAR ----- ± .000 ANGULAR ----- ± 0°00'
	BY	DATE		SCALE NONE
STK No:				PLOT HALF
MAT'L:				
DESCR.	BALL CORPORATION VALVE (AWWA IP x PEP\PVC(IPS) PACK JOINT)			DWG NUMBER E25029N

TITLE TO AND OWNERSHIP OF THIS ENGINEERING
 DATA REMAINS IN Mueller Co. NO USE IS TO BE
 MADE OF THIS DATA EXCEPT AS SPECIFICALLY
 AUTHORIZED BY Mueller Co. ASSENT ON THE PART
 OF THE RECIPIENT TO THESE CONDITIONS IS PRESUMED

DWG NUMBER
E25029N