

No.	DESCRIPTION	MATERIAL DESCRIPTION
1	BODY	CAST LOW LEAD BRASS ALLOY
2	CAP	CAST LOW LEAD BRASS ALLOY
3	STEM	LOW LEAD BRASS ALLOY
4	BALL	LOW LEAD BRASS ALLOY
5	GASKET	ASTM D2000 (NITRILE)
6	SOLID PIN	AISI 303 STAINLESS STEEL
7	O-RING	ASTM D2000 (EP)
8	END PIECE	CAST BRASS ASTM B62 ALLOY C83600
9	O-RING	ASTM D2000 (EP)
10	PJ GASKET	BUNA-N ASTM D2000
11	PJ WASHER	POLYPROPYLENE
12	COMPRESSION RING	BRASS ASTM B505 ALLOY C83600
13	COMPRESSION NUT	CAST BRASS ASTM B62 ALLOY C83600

SIZE	øA	B	C	D	E
3/4"R	.63	3.21	.75	2.12	2.87
3/4"	.75	3.36	.84	2.43	3.27
3/4x1	.75	3.59	.84	2.43	3.27
1"R	.75	3.77	.84	2.43	3.27
1"	1.00	4.52	1.15	2.57	3.72
1-1/2"	1.50	4.69	1.50	3.37	4.87
2"	2.00	5.22	1.82	3.92	5.74

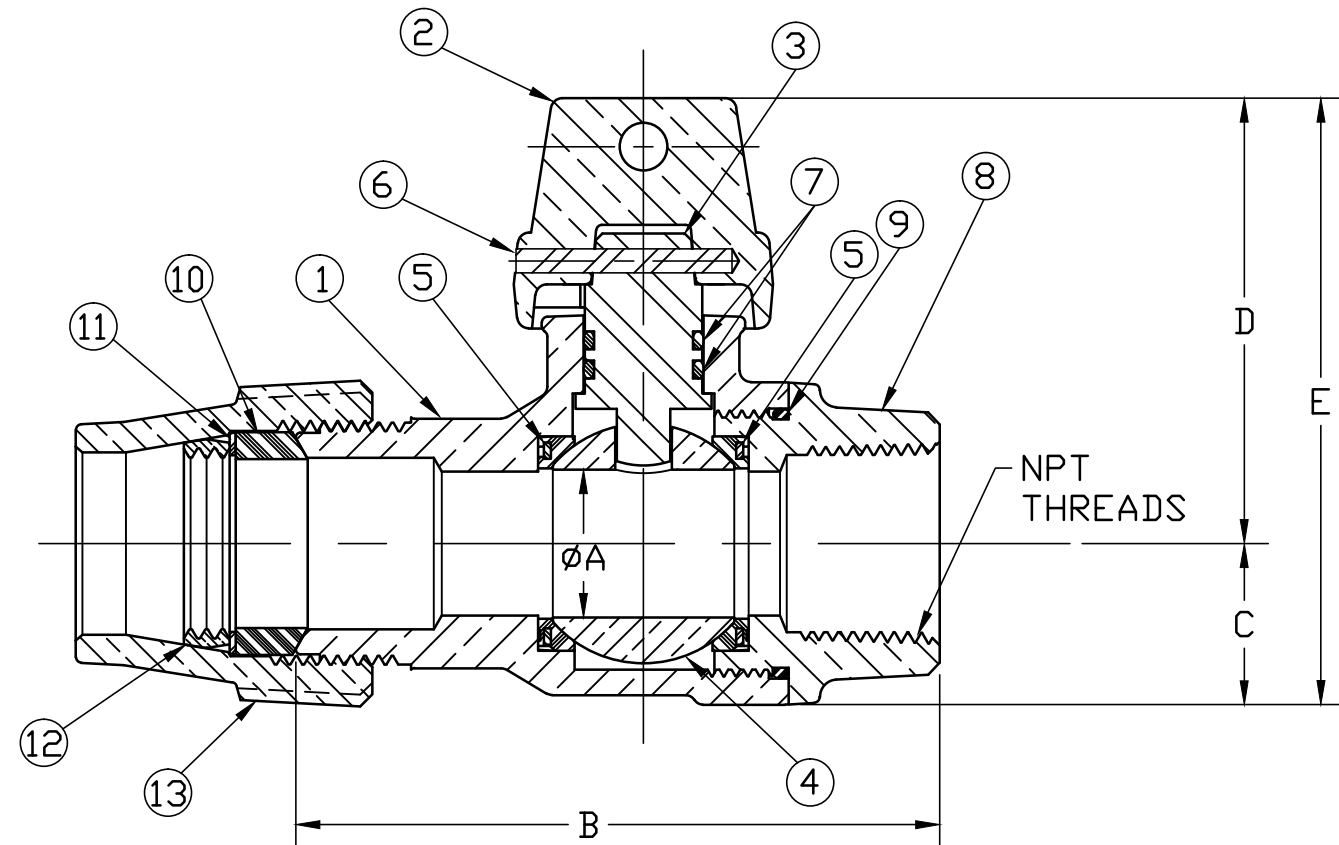

ALL WETTED PARTS ARE LOW LEAD BRASS ALLOY

FILEPATH: PROD-ENG\MUELLER\ASYSUBMITTALS\G25172N

DRFTR	RWB	4/23/14	Mueller Co.		
CHKR					
ENGR					
MGR					
			UNLESS OTHERWISE NOTED	THIRD ANGLE PROJECTION	
			SURFACE PREPARATION:		
			BREAK CORNER(S) ---- .000		
			SURFACE FINISH --XXX RMS	REF. No.	
			TOLERANCE(S):	SCALE	
			LINEAR ----- ± .000	FULL	
			ANGULAR ----- ± 0°00'		
			STK No:		
			MAT'L:		
			DESCR.		
			INLINE LLB BALL CURB VALVE	DWG NUMBER	
			(CTS GRIP x FIP)	G25172N	
REV	ECR	DESCRIPTION	DATE	BY	CHKR
PER EST NO: DXXXX EST FIN WT = 0.0000 lbs					

DWG NUMBER
G25172N
442-MRKTG

TITLE TO AND OWNERSHIP OF THIS ENGINEERING DATA REMAINS IN Mueller Co. NO USE IS TO BE MADE OF THIS DATA EXCEPT AS SPECIFICALLY AUTHORIZED BY Mueller Co. ASSENT ON THE PART OF THE RECIPIENT TO THESE CONDITIONS IS PRESUMED.