

ACTUATOR POSITION 1

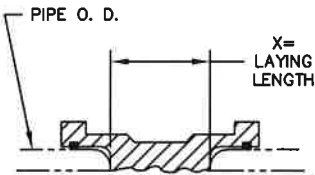

INSTALLATION DIAGRAM  
RUBBER RING GASKETS  
FURNISHED BY OTHERS

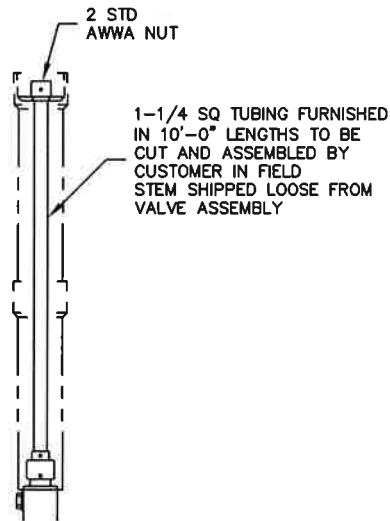

OPTIONAL EXTENSION  
STEM ARRANGEMENT

NOTES:

1. ALL DIMENSIONS SHOWN IN INCHES.
2. "D" DIMENSION  $\pm 1/16"$  FOR 4" THRU 10" VALVES.  
"D" DIMENSION  $\pm 1/8"$  FOR 12" THRU 16" VALVES.
3. VALVES MANUFACTURED & TESTED IN ACCORDANCE WITH AWWA SPECIFICATION C-504 LATEST REVISION, CLASS 150B.
4. USE WITH 'TYTON' RUBBER RING GASKET (REG T.M. OF U. S. PIPE AND FOUNDRY CO.)
5. THE VALVE IS DESIGNED FOR IRON OR PVC PIPE WITH CAST IRON EQUIVALENT O D'S (NOT FOR USE WITH IPS O D PIPE)
6. EXTENSION STEM CAN BE USED WITH STANDARD VALVE BOXES OR 5" SOIL PIPE
7. ALSO AVAILABLE IN 24" SIZE, DIMENSIONS AVAILABLE UPON REQUEST.

PIPE SIZE	PIPE O. D.	MIN. MATING I. D.
4	4.80	2.61
6	6.90	4.96
8	9.05	7.22
10	11.10	9.22
12	13.20	10.97
14	15.65	12.56
16	17.80	14.59

VALVE SIZE	A	B	C	D	X
4	5-1/2	4-1/8	6-3/8	10-3/8	3-1/8
6	6-1/2	5-1/8	9	10-3/4	3-1/2
8	7-3/4	6-1/2	11-1/4	12	3-5/8
10	9	9-7/8	14	12-5/8	4-1/8
12	10-1/2	11-3/8	16-3/8	15	5-1/8
14	11-7/8	12-5/8	18-7/8	14-3/4	4-1/2
16	13-1/2	14-1/2	21-1/4	15	4-3/4

ACTUATOR SIZE	J	L	M	N	P	Q	R	NUMBER OF TURNS
MDT-2S	4-11/16	2	2-1/8	2	4-1/2	4-1/2	8-1/4	32
MDT-3S	5-5/8	2-7/16	3-1/4	3-5/32	5-5/8	5-3/8	10-3/8	30
MDT-4S	6-3/8	2-27/32	3-3/8	4	7-5/16	6-3/4	11-5/16	40
MDT-5	7-9/16	3-15/32	4-1/2	5-1/2	8-3/4	10	17	44

REV	DATE	BY	DESCRIPTION	APP.
1	3/21/18	JUR	UPDATED TITLE BLOCK	

**(Mueller Co.)**

4" - 16" LINESEAL III  
PUSH-ON ENDS  
MDT BURIED SERVICE ACTUATOR

SCALE NONE DATE 1-29-09

DRAWN BY CEM CHECKED BY JR

APPROVED \_\_\_\_\_ GA=BORDER

DRWG. NO. GA-11866MS REV 1 AC