

ITEM NO.	PART NUMBER	DESCRIPTION	QTY.
1	538614E	METER ADAPTER, 1" METER NUT x 2" FLANGE	1
2	526462	METER NUT	1
3	052419	RUBBER GASKET	1

REVISIONS					
REV.	ECR	DESCRIPTION	DRAFTER	DATE	APPROVED

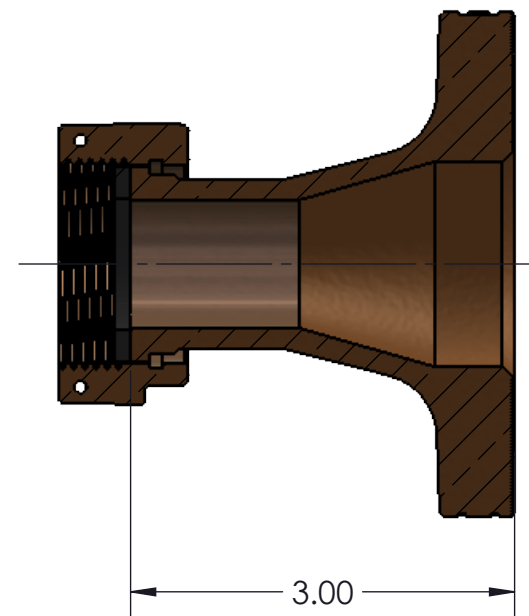
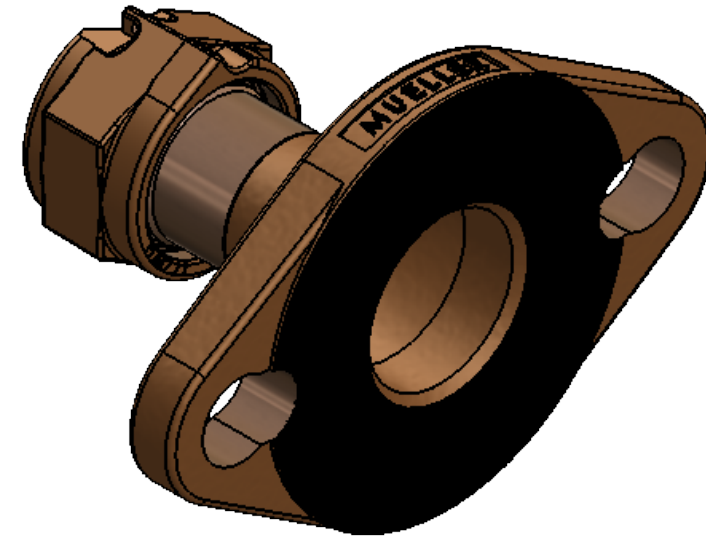
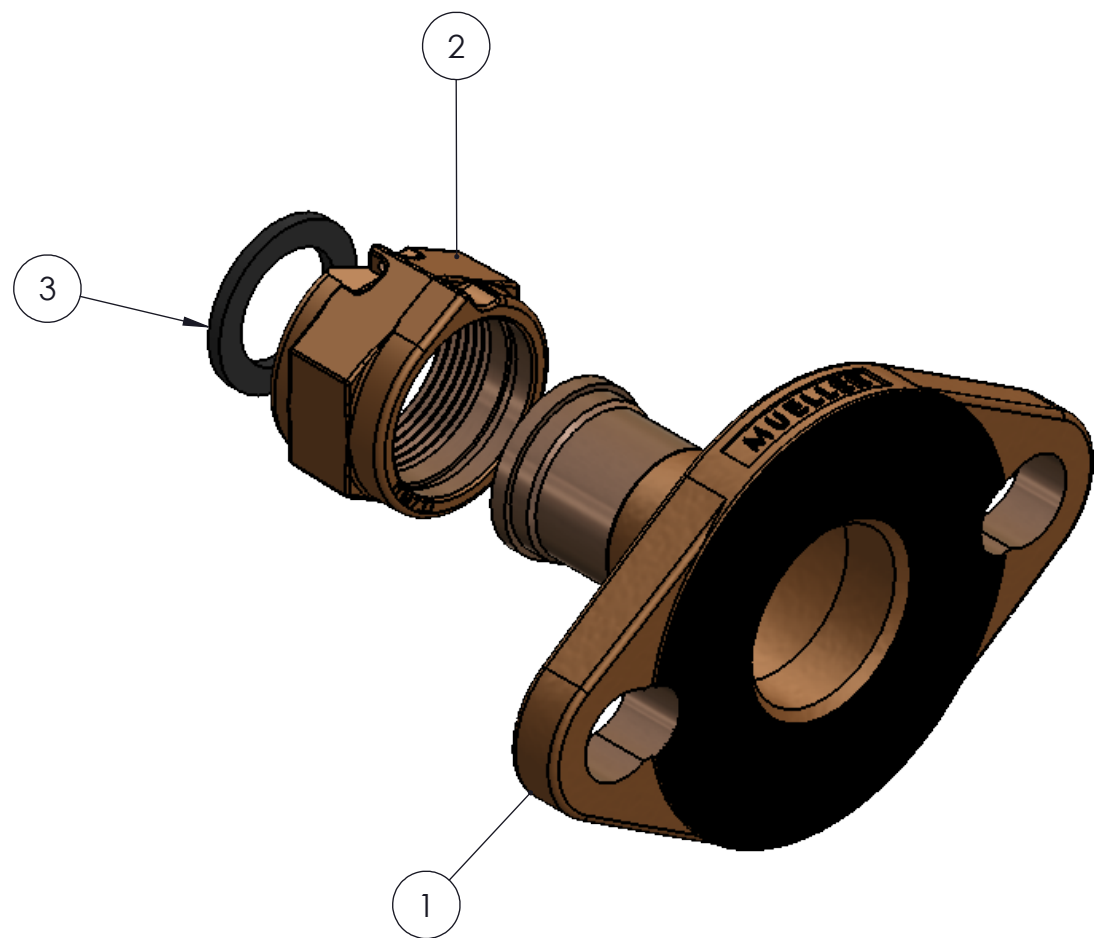

UNLESS OTHERWISE SPECIFIED:
 DIMENSIONS ARE IN INCHES
 MACHINING TOLERANCES:
 ANGULAR: MACH ±30°
 BEND ±30°
 ONE PLACE DECIMAL ±0.1
 TWO PLACE DECIMAL ±0.015
 THREE PLACE DECIMAL ±0.005
 BREAK CORNERS .015
 FINISH $\sqrt{125}$ RMS

	NAME	DATE
DRAFTER	ATJ	27-NOV-18
P.E. APPR.	XXX	XXX
M.E. APPR.	XXX	XXX
Q.A. APPR.	XXX	XXX



TITLE:
 1" METER SWIVEL NUT x 2" METER
 FLANGE, BRASS ONLY

MATERIAL
 ASSEMBLY
 STK. NUMBER NONE
 REF. NO. NONE

DO NOT SCALE DRAWING
 ○ = CRITICAL () = REFERENCE

SIZE **B**
 DWG. NUMBER H-10879 337N
 REV -
 SCALE: 2:3 WT: 3.2640 lbs SHEET 1 OF 1

TITLE TO AND OWNERSHIP OF THIS ENGINEERING DATA REMAINS IN Mueller Co. NO USE IS TO BE MADE OF THIS DATA EXCEPT AS SPECIFICALLY AUTHORIZED BY Mueller Co. ASSENT ON THE PART OF THE RECIPIENT TO THESE CONDITIONS IS PRESUMED