

No.	DESCRIPTION	MATERIAL
1	BUSHING	CAST LOW LEAD BRASS ALLOY

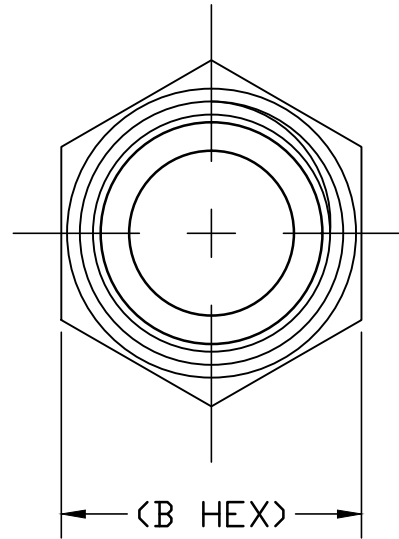
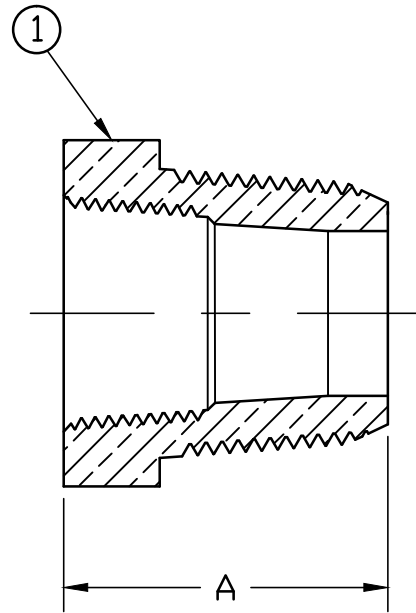

SIZE	A	B
1" x 3/4"	1.688	1.562
1-1/2" x 1"	2.125	2.281
2" x 3/4"	2.375	1.922
2" x 1-1/2"	2.375	1.938

ALL WETTED PARTS ARE LOW LEAD BRASS ALLOY

FILEPATH: PROD-ENG\MUELLER\ASYSUBMITTALS\H10036N

						DRFTR	RWB	4/12/16	Mueller Co.	THIRD ANGLE PROJECTION 		
						CHKR						
						ENGR				UNLESS OTHERWISE NOTED SURFACE PREPARATION: BREAK CORNER(S) ---- .000 SURFACE FINISH -- XX RMS TOLERANCE(S): LINEAR ----- ± .000 ANGULAR ----- ± 0°00'	REF. No.	SCALE
						MGR						
							BY	DATE				
							STK No:					
							MAT'L:					
							DESCR.		LLB BUSHING ("CC" TAPER x MIP)			
										DWG NUMBER H10036N		
REV	ECR	DESCRIPTION	DATE	BY	CHKR	PER EST NO: DXXXX EST FIN WT = 0.0000 lbs						

DWG NUMBER
H10036N
442-MRKTG

TITLE TO AND OWNERSHIP OF THIS ENGINEERING DATA REMAINS IN Mueller Co. NO USE IS TO BE MADE OF THIS DATA EXCEPT AS SPECIFICALLY AUTHORIZED BY Mueller Co. ASSENT ON THE PART OF THE RECIPIENT TO THESE CONDITIONS IS PRESUMED.