

No.	DESCRIPTION	MATERIAL
1	SPUD	CAST LOW LEAD BRASS ALLOY
2	CONN. NUT	CAST BRASS ASTM B62 ALLOY C83600
3	CTS GSKT SUB	SBR ASTM D2000 - GSKT 410ss - BAND
4	SADDLE NUT	CAST BRASS ASTM B62 ALLOY C83600
5	SNAP RING	PHOS BRONZE
6	RUBBER GASKET	NITRILE ASTM D2000

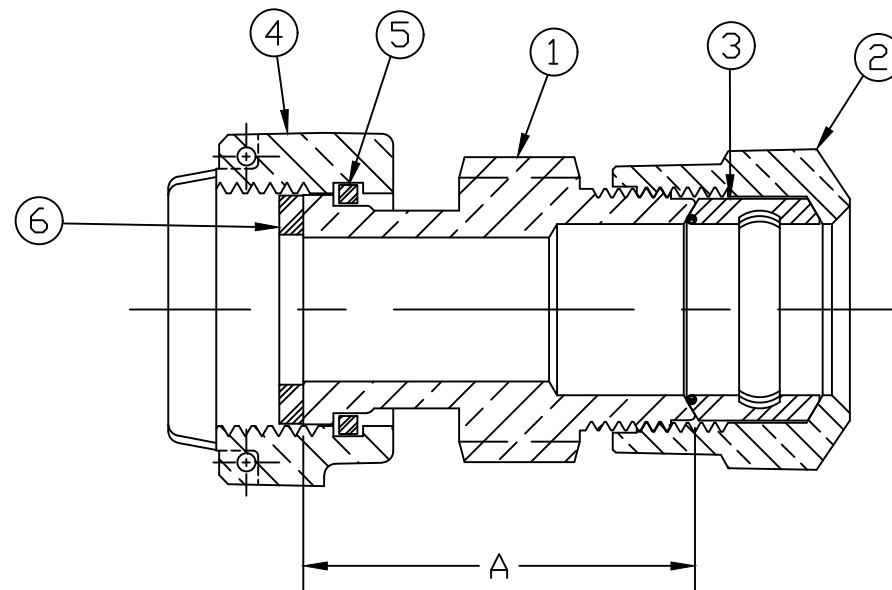

SIZE	A
3/4"	2-3/8"
5/8" x 3/4" x 1"	2-3/16"
1"	2-5/32"

ALL WETTED PARTS ARE LOW LEAD BRASS ALLOY

FILEPATH: PROD-ENG\MUELLER\ASYSUBMITTALS\H14201N

						DRFTR JGarvin 4/26/11	MUELLER	UNLESS OTHERWISE NOTED THIRD ANGLE PROJECTION SURFACE PREPARATION: BREAK CORNER(S) ---- .000 SURFACE FINISH -- XX RMS TOLERANCE(S): LINEAR ----- ± .000 ANGULAR ----- ± 0°00'	REF. No. SCALE
						CHKR			
						ENGR			
						MGR			
						BY	DATE		
						STK No:			
						MAT'L:			
						DESCR.	STRAIGHT METER COUPLING - LLB (METER SADDLE SWIVEL NUT x 110 CTS)		DWG NUMBER H14201N
REV	ECR	DESCRIPTION	DATE	BY	CHKR	PER EST NO: DXXXX EST FIN WT = 0.0000 lbs			

TITLE TO AND OWNERSHIP OF THIS ENGINEERING DATA REMAINS IN Mueller Co. NO USE IS TO BE MADE OF THIS DATA EXCEPT AS SPECIFICALLY AUTHORIZED BY Mueller Co. ASSENT ON THE PART OF THE RECIPIENT TO THESE CONDITIONS IS PRESUMED

DWG NUMBER
H14201N
442-MRKTG