

SIZE	A	B	NPT SIZE
1-1/2"	1.81	2.56	1-1/2"
2"	2.19	2.88	2"

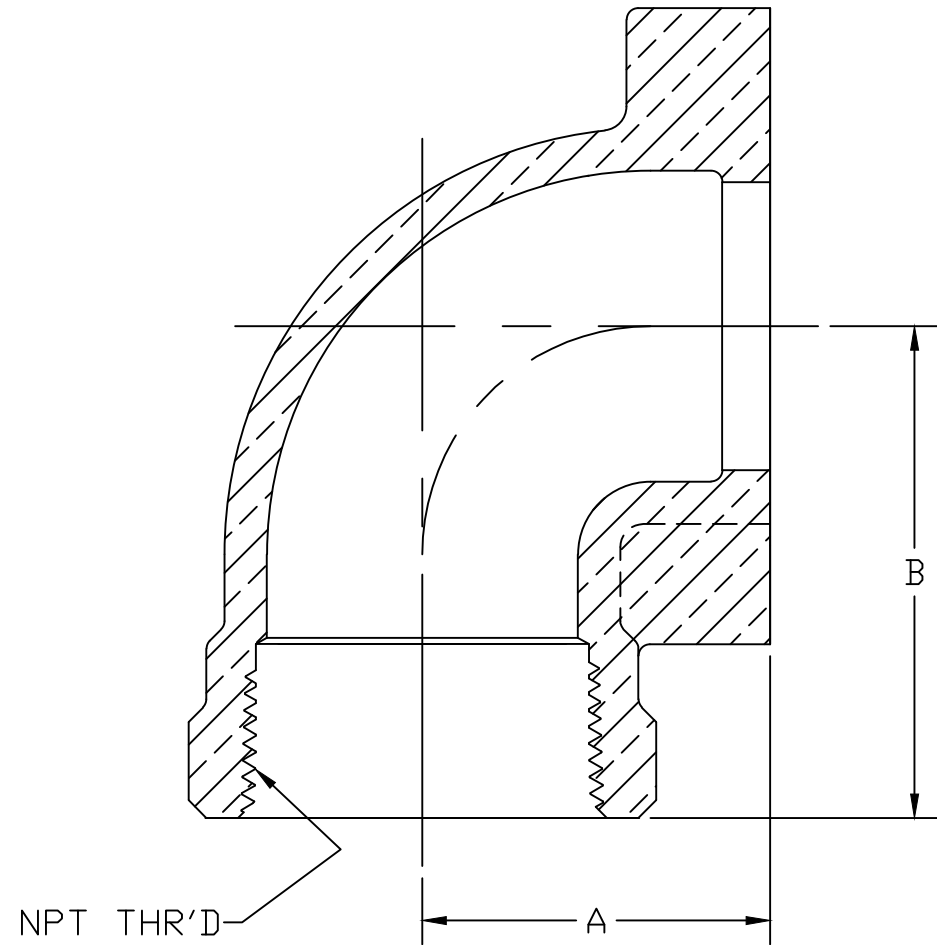

No.	DESCRIPTION	MATERIAL
1	SPUD	LEAD FREE BRASS ALLOY ASTM B584
2	GROOVED PIN	CAST BRASS ALLOY ASTM B584

PIN NOT SHOWN ON ASS'Y

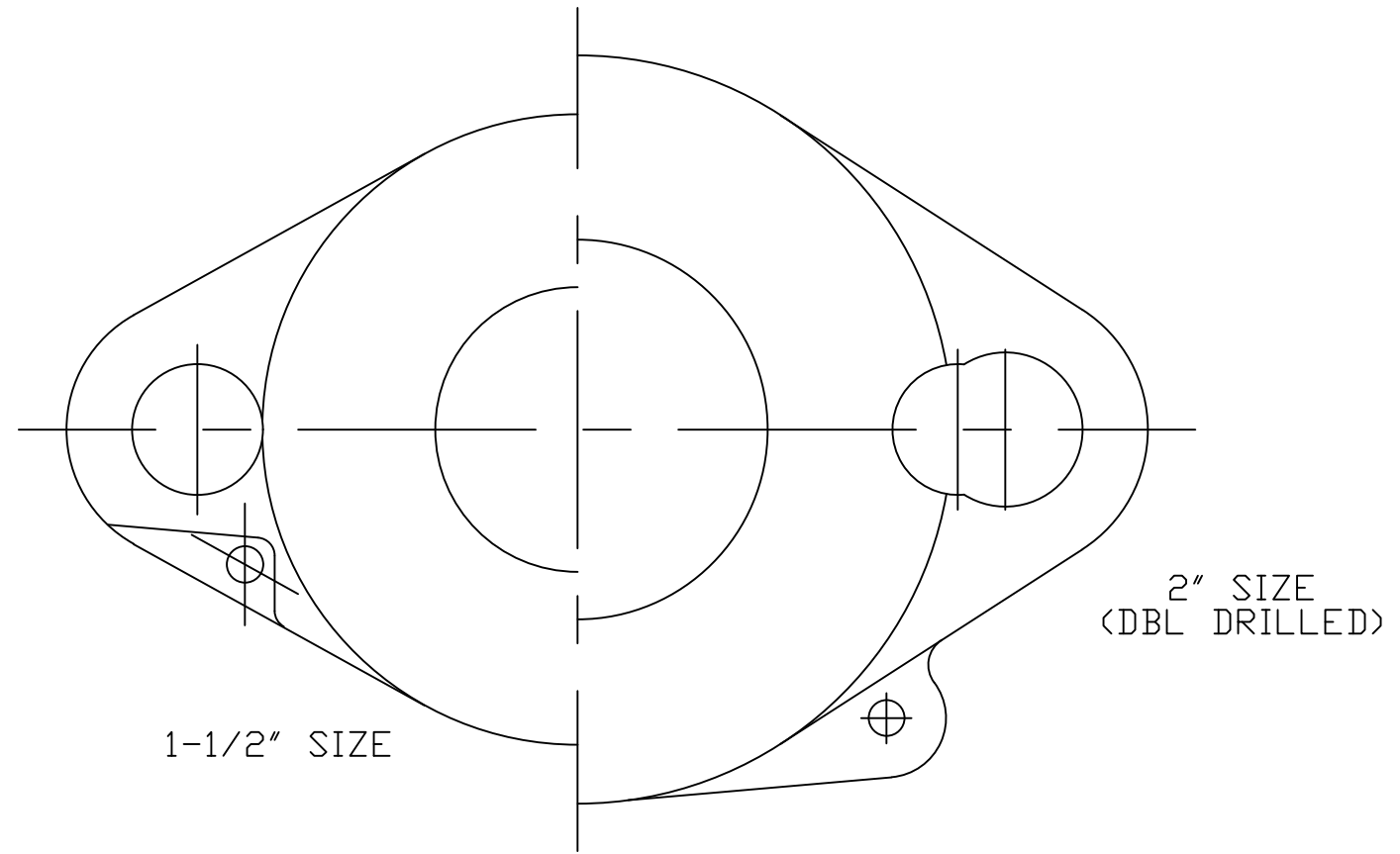

MEETS ALL REQUIREMENTS OF AWWA C800
 ALL WETTED PARTS ARE LEAD FREE BRASS ALLOY C89833/C87850
 ALL NON WETTED PARTS ARE BRASS ALLOY C83600/C87850

DWG NUMBER
H14204N

TITLE TO AND OWNERSHIP OF THIS ENGINEERING
 DATA REMAINS IN Mueller Co. NO USE IS TO BE
 MADE OF THIS DATA EXCEPT AS SPECIFICALLY
 AUTHORIZED BY Mueller Co. ASSENT ON THE PART
 OF THE RECIPIENT TO THESE CONDITIONS IS PRESUMED

DRFTR	AD	02/20/23	MUELLER			
CHKR						
ENGR			UNLESS OTHERWISE NOTED	THIRD ANGLE PROJECTION		
MGR						
			SURFACE PREPARATION:		REF. No.	SCALE
			BREAK CORNER(S) ---- .000			
			SURFACE FINISH -- XX RMS			
	BY	DATE	TOLERANCE(S):			
			LINEAR ----- ± .000			
			ANGULAR ----- ± 0°00'			
STK No:			MAT'L:			
DESCR.	QUARTER BEND METER COUPLING (FIP x METER FLANGE)				DWG NUMBER H14204N	