

No.	DESCRIPTION	MATERIAL
1	SPUD	CAST LOW LEAD BRASS ALLOY
2	CONN. NUT	CAST BRASS ASTM B62 ALLOY C83600
3	CTS GSKT SUB	SBR D2000 - GSKT 410ss - BAND
4	METER NUT	CAST BRASS ASTM B62 ALLOY C83600
5	SNAP RING	COPPER ALLOY CDA 521
6	RUBBER GASKET	NITRILE ASTM D2000

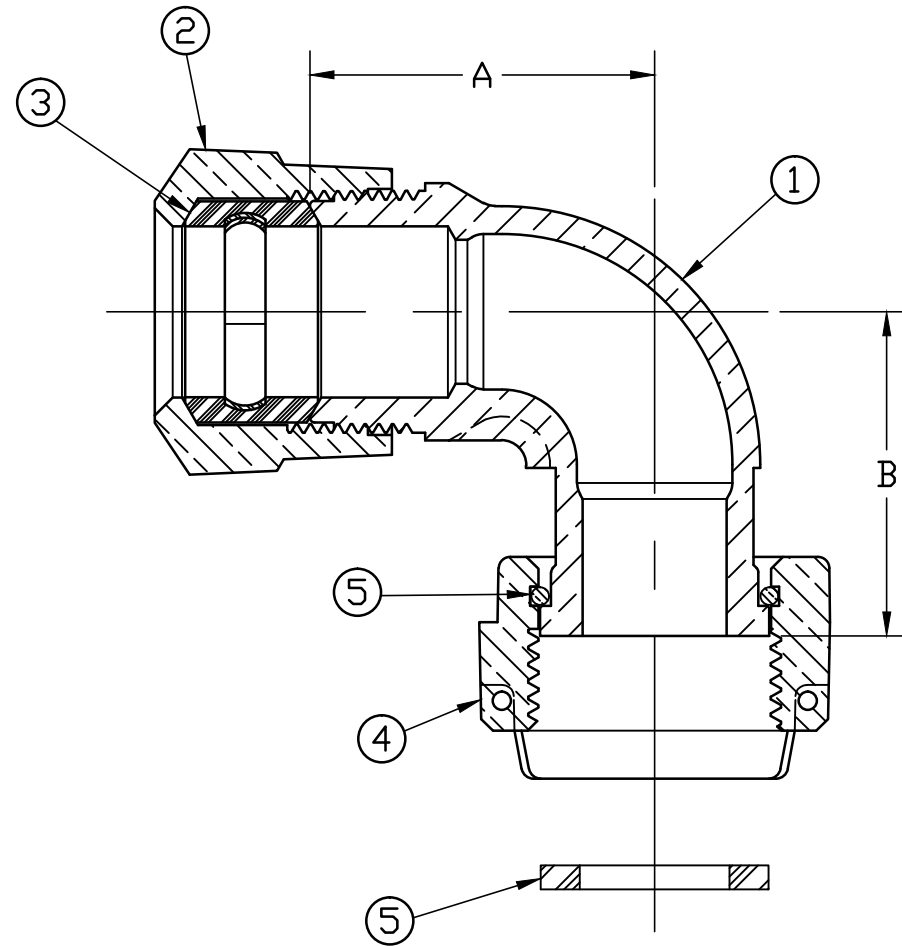

SIZE	A	B
5/8 x 3/4 x 3/4	1.80	1.69
1	2.00	1.88

ALL WETTED PARTS ARE LOW LEAD BRASS ALLOY

FILEPATH: PROD-ENG\MUELLER\ASYSUBMITTALS\H14206N

						DRFTR	RWB	6/6/14	<b>Mueller Co.</b>	UNLESS OTHERWISE NOTED THIRD ANGLE PROJECTION SURFACE PREPARATION: BREAK CORNER(S) ---- .000 SURFACE FINISH -- XX RMS TOLERANCE(S): LINEAR ----- ± .000 ANGULAR ----- ± 0°00'	REF. No.	SCALE NONE				
						CHKR										
						ENGR										
						MGR										
							BY	DATE	STK No:							
									MAT'L:							
									DESCR.	QUARTER BEND LLB METER COUPLING (110 CTS x METER)		DWG NUMBER H14206N				
									REV	ECR	DESCRIPTION	DATE	BY	CHKR	PER EST NO: DXXXX	EST FIN WT = 0.0000 lbs

TITLE TO AND OWNERSHIP OF THIS ENGINEERING DATA REMAINS IN Mueller Co. NO USE IS TO BE MADE OF THIS DATA EXCEPT AS SPECIFICALLY AUTHORIZED BY Mueller Co. ASSENT ON THE PART OF THE RECIPIENT TO THESE CONDITIONS IS PRESUMED.

DWG NUMBER  
H14206N  
442-MRKTG