

No.	DESCRIPTION	MATERIAL
1	RUBBER GASKET	NITRILE D2000
2	SNAP RING	COPPER ALLOY CDA521
3	SADDLE NUT	CAST BRASS ALLOY ASTM B584
4	TAILPIECE	LEAD FREE BRASS ALLOY ASTM B584

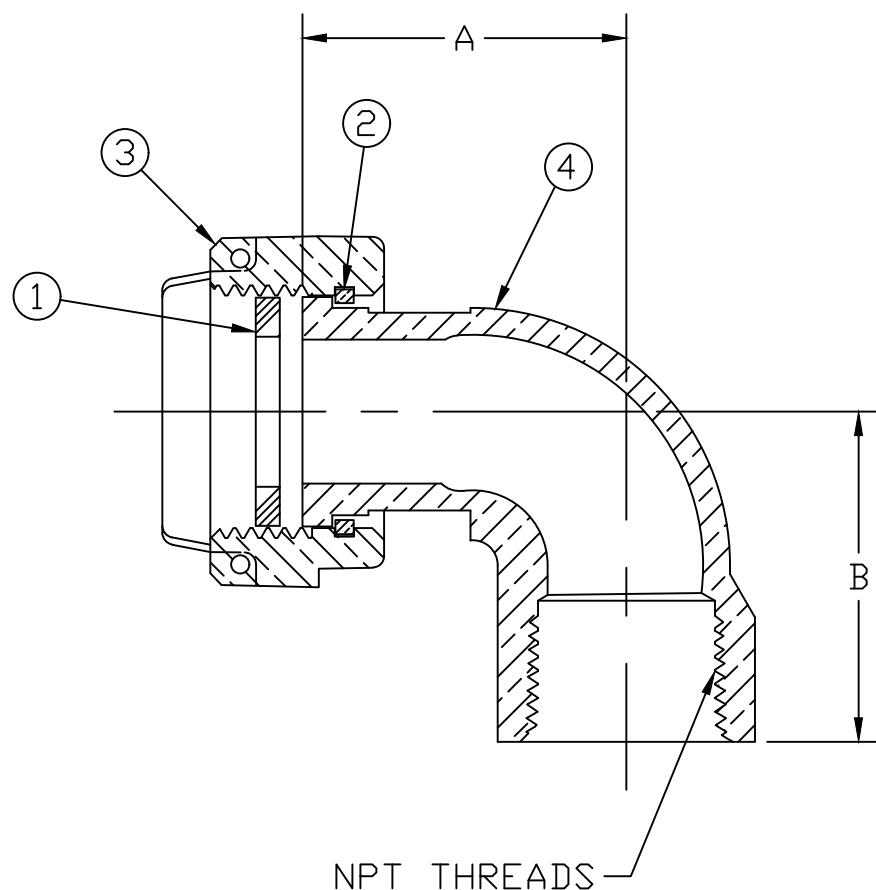

METER CONNX SIZE	A	B
5/8 x 3/4	1.688	1.625
5/8 x 3/4 x 3/4	1.688	1.719
1	1.875	2.000

MEETS ALL REQUIREMENTS OF AWWA C800  
 ALL WETTED PARTS ARE LEAD FREE BRASS ALLOY C89833/C87850  
 ALL NON WETTED PARTS ARE BRASS ALLOY C83600/C87850

DRFTR	AD	02/20/23	<b>MUELLER</b>		
CHKR					
ENGR			UNLESS OTHERWISE NOTED SURFACE PREPARATION: BREAK CORNER(S) ----- .000 SURFACE FINISH -- XX RMS	THIRD ANGLE PROJECTION	
MGR				REF. No.	SCALE
	BY	DATE	TOLERANCE(S): LINEAR ----- ± .000 ANGULAR ----- ± 0°00'		NONE
STK No:			MAT'L:		
DESCR.			QUARTER BEND WATER COUPLING (METER x FIP)		DWG NUMBER H14210N

DWG NUMBER  
H14210N

TITLE TO AND OWNERSHIP OF THIS ENGINEERING  
 DATA REMAINS IN Mueller Co. NO USE IS TO BE  
 MADE OF THIS DATA EXCEPT AS SPECIFICALLY  
 AUTHORIZED BY Mueller Co. ASSENT ON THE PART  
 OF THE RECIPIENT TO THESE CONDITIONS IS PRESUMED