

METER SIZE	1-1/2"	2"
A (MINIMUM)	12"	12"
B	13-1/4"	17-1/4"
DUAL ANGLE CHECK VALVE	500HI4244N	550HI4244N
ANGLE METER STOP	500HI42860IN	550HI42860IN
PLUGGED TEE	527324E	546234E

ITEM NO	PART NUMBER	QTY	DESCRIPTION
1	681558	1	TIE BAR SUB ASSEMBLY
2	330HI5428N	1	1" MIP X 1" CTS COMPRESSION TAILPIECE
3		2	PLUGGED TEE (FNPT X SOLDER X 1" FNPT)
4	HI4244N	1	DUAL CHECK VALVE
5	HI42860IN	1	ANGLE METER STOP
6		2	RISER SUB ASSEMBLY

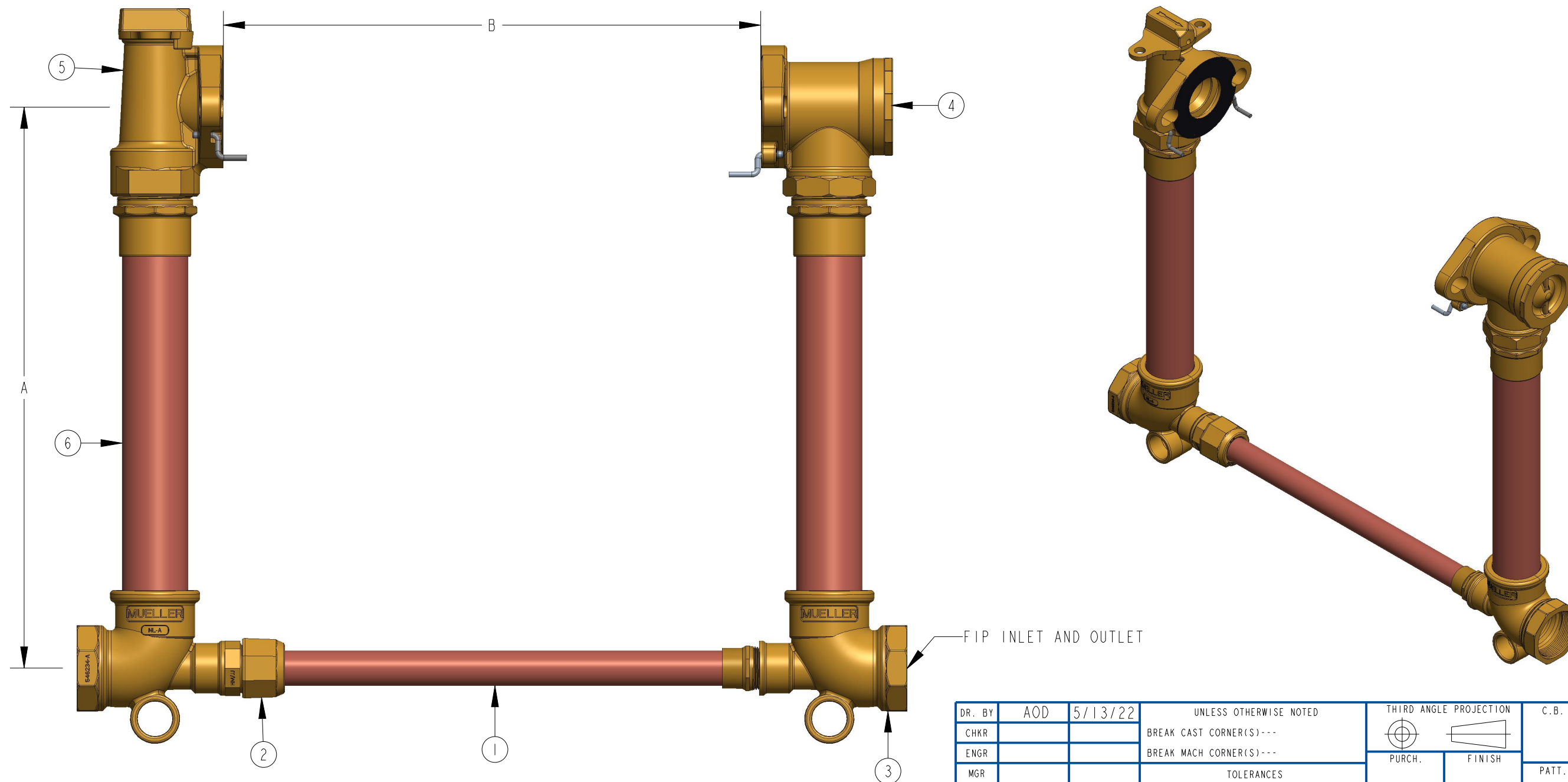

DR. BY	AOD	5/13/22	UNLESS OTHERWISE NOTED		THIRD ANGLE PROJECTION		C.B. NO.
CHKR			BREAK CAST CORNER(S)---				
ENGR			BREAK MACH CORNER(S)---		PURCH.	FINISH	PATT. NO.
MGR			TOLERANCES		REF. NO.	SCALE	
MFG			UNLESS OTHERWISE NOTED		STK. NO.	NONE	
TOOL			LINEAR	ANGULAR			
FDY			±	±			

MAT'L:		
MUELLER	DESCR. COPPER METER SETTER LOW LEAD BRASS	NUMBER HI422--2---N

HI422--2---N