

No.	DESCRIPTION	MATERIAL
1	TAILPIECE	LEAD FREE BRASS ALLOY ASTM B584
2	COUP. NUT	CAST BRASS ALLOY ASTM B584
3	GASKET	RED FIBER, ASTM D710
4	FORM	20# BOND PAPER

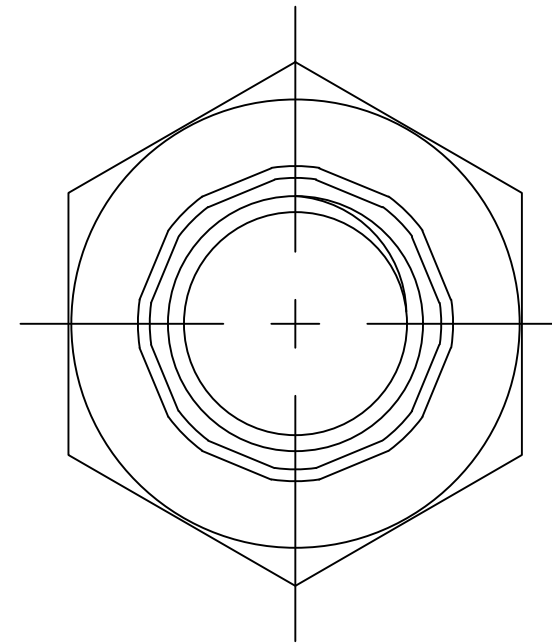
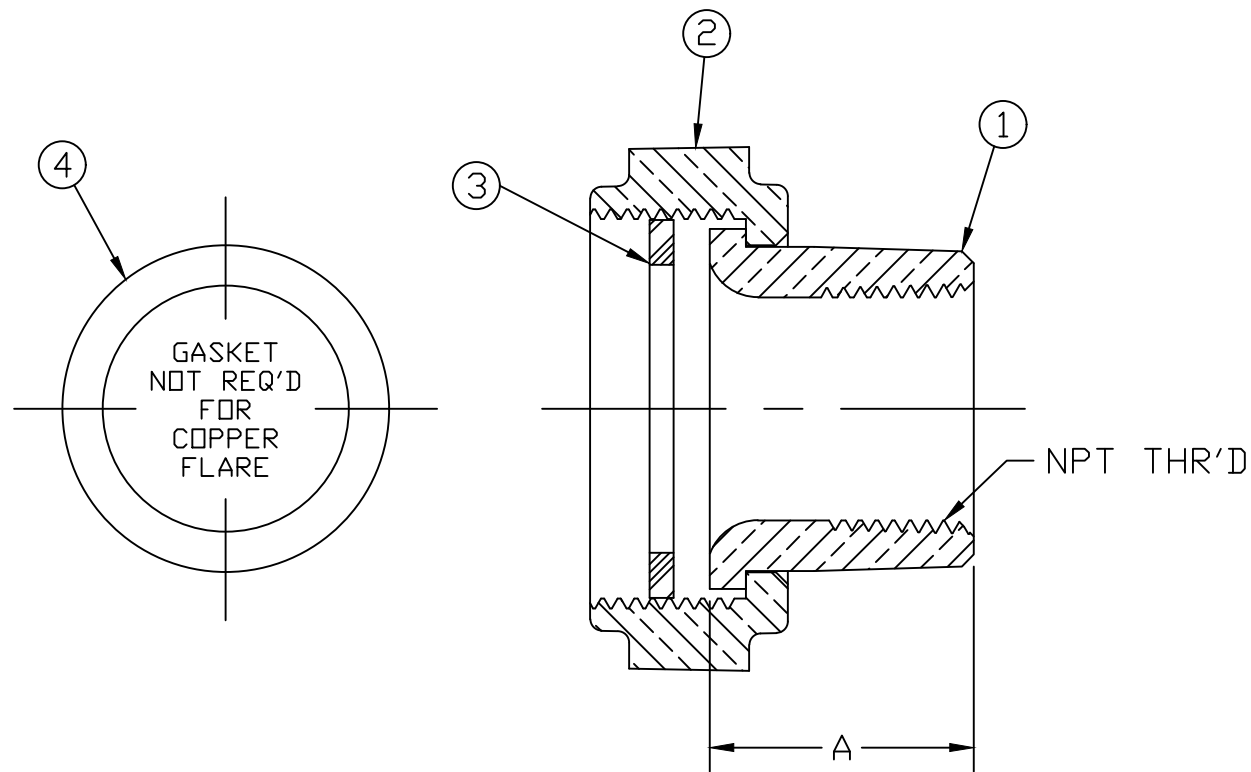

SIZE	A	NPT
5/8"x3/4"x3/4"	1.00	3/4"
1"	1.38	1"

MEETS ALL REQUIREMENTS OF AWWA C800  
 ALL WETTED PARTS ARE LEAD FREE BRASS ALLOY C89833/C87850  
 ALL NON WETTED PARTS ARE BRASS ALLOY C83600/C87850

DWG NUMBER  
H14222N

TITLE TO AND OWNERSHIP OF THIS ENGINEERING  
 DATA REMAINS IN Mueller Co. NO USE IS TO BE  
 MADE OF THIS DATA EXCEPT AS SPECIFICALLY  
 AUTHORIZED BY Mueller Co. ASSENT ON THE PART  
 OF THE RECIPIENT TO THESE CONDITIONS IS PRESUMED

DRFTR	AD	03/15/23	<b>MUELLER</b>	
CHKR				
ENGR			UNLESS OTHERWISE NOTED	THIRD ANGLE PROJECTION
MGR				SURFACE PREPARATION: BREAK CORNER(S) ---- .000 SURFACE FINISH -- XX RMS
	BY	DATE	TOLERANCE(S): LINEAR ----- ± .000 ANGULAR ----- ± 0°00'	SCALE
STK No:				FULL
MAT'L:				
DESCR.			METER YOKE COUPLING (FIP x MULTI PURPOSE)	DWG NUMBER H14222N