

No.	DESCRIPTION	MATERIAL
1	GASKET	RUBBER
2	SPUD	LEAD FREE BRASS ALLOY ASTM B584
3	COUPLING NUT	CAST BRASS ALLOY ASTM B584
4	GASKET	ASTM D2000 (BUNA N) RUBBER
5	WASHER	POLYPROPYLENE
6	SET SCREW	ZINC PLATED STEEL

SIZE	A
1-1/2"	3.250
2"	3.750

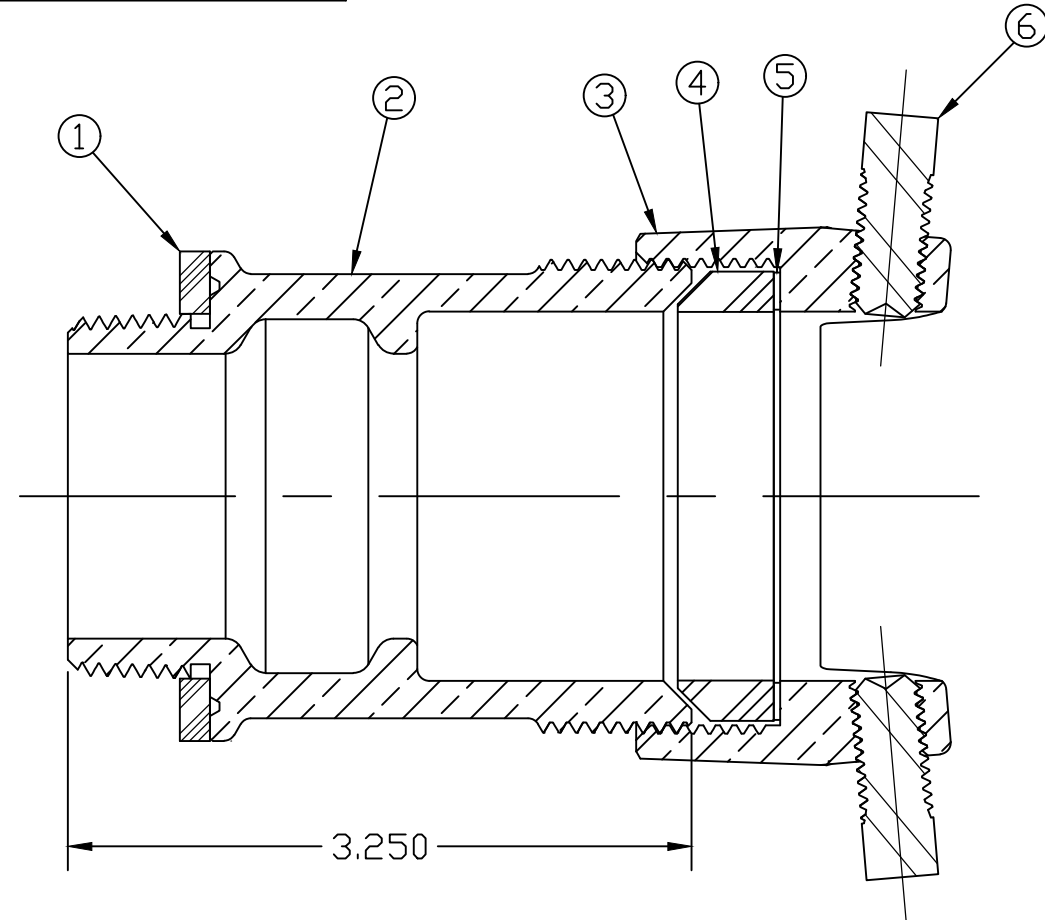

MEETS ALL REQUIREMENTS OF AWWA C800
 ALL WETTED PARTS ARE LEAD FREE BRASS ALLOY C89833/C87850
 ALL NON WETTED PARTS ARE BRASS ALLOY C83600/C87850

DWG NUMBER
H14239N

TITLE TO AND OWNERSHIP OF THIS ENGINEERING
 DATA REMAINS IN Mueller Co. NO USE IS TO BE
 MADE OF THIS DATA EXCEPT AS SPECIFICALLY
 AUTHORIZED BY Mueller Co. ASSENT ON THE PART
 OF THE RECIPIENT TO THESE CONDITIONS IS PRESUMED

DRFTR	AD	02/10/23	MUELLER	
CHKR				
ENGR			UNLESS OTHERWISE NOTED	THIRD ANGLE PROJECTION
MGR				SURFACE PREPARATION: BREAK CORNER(S) ---- .000 SURFACE FINISH -- XX RMS
	BY	DATE	TOLERANCE(S): LINEAR ----- ± .000 ANGULAR ----- ± 0°00'	SCALE
STK No:				FULL
MAT'L:				
DESCR.			METER COUPLING (TMT x COMP FOR STEEL PIPE)	DWG NUMBER H14239N