

No.	DESCRIPTION	MATERIAL
1	KEY CAP	CAST BRASS ASTM B62 ALLOY C83600
2	PIN	BRASS ASTM B16 ALLOY C36000
3	SPRING WASHER	PHOS BRONZE
4	O-RING	EPDM ASTM D2000
5	KEY	CAST LOW LEAD BRASS ALLOY
6	BODY	CAST LOW LEAD BRASS ALLOY
7	SADDLE NUT	CAST BRASS ASTM B62 ALLOY C83600
8	SNAP RING	PHOS BRONZE
9	RUBBER GASKET	NITRILE ASTM D2000
10	SPUD	CAST LOW LEAD BRASS ALLOY
11	CONNECTING RING	LOW LEAD BRASS ALLOY

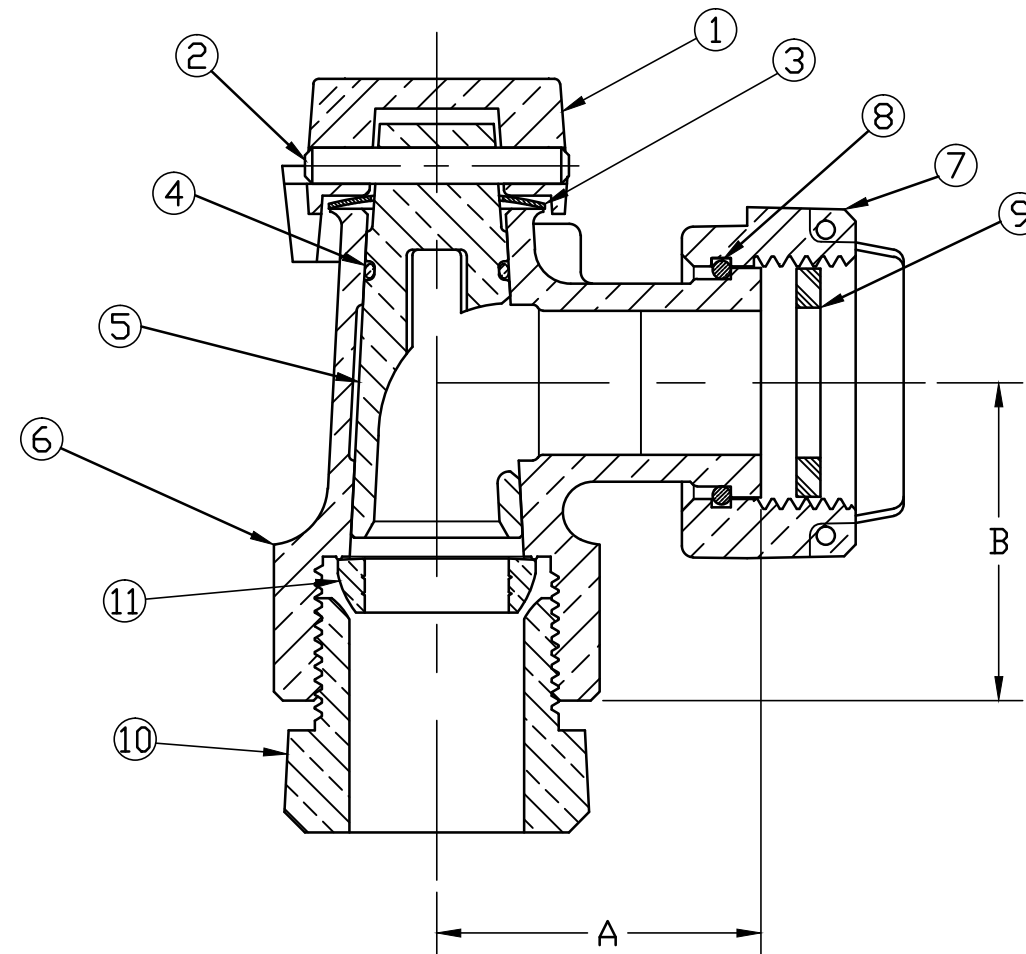

METER CONNX SIZE	A	B
5/8 x 3/4 x 3/4	1.69	1.66
1	1.94	2.25

NOTE: ALL WETTED PARTS ARE LOW LEAD BRASS ALLOY

FILEPATH: PROD-ENG\MUELLER\ASYSUBMITTALS\H1425530N

DRFTR	RWB	3/10/14	Mueller Co.		
CHKR					
ENGR					
MGR					
			UNLESS OTHERWISE NOTED	THIRD ANGLE PROJECTION	
			SURFACE PREPARATION:		
			BREAK CORNER(S) ---- .000		
			SURFACE FINISH -- XX RMS	REF. No.	
			TOLERANCE(S):	SCALE	
			LINEAR ----- ± .000	FULL	
			ANGULAR ----- ± 0°00'		
			BY	DATE	
			STK No:		
			MAT'L:		
			DESCR.		
			ANGLE METER STOP	DWG NUMBER	
			LOW LEAD BRASS (1957 CS x MTR)	H1425530N	
REV	ECR	DESCRIPTION	DATE	BY	CHKR
PER EST NO: DXXXX EST FIN WT = 0.0000 lbs					

DWG NUMBER
H1425530N
442-MRKTG

TITLE TO AND OWNERSHIP OF THIS ENGINEERING DATA REMAINS IN Mueller Co. NO USE IS TO BE MADE OF THIS DATA EXCEPT AS SPECIFICALLY AUTHORIZED BY Mueller Co. ASSENT ON THE PART OF THE RECIPIENT TO THESE CONDITIONS IS PRESUMED