

No.	QTY.	DESCRIPTION	MATERIAL
1	1	KEY CAP	CAST BRASS ASTM B62 ALLOY C83600
2	1	PIN	BRASS ASTM B16 ALLOY C36000
3	1	SPRING WASHER	PHOS BRONZE
4	1	O-RING	EPDM ASTM D2000
5	1	KEY	CAST NO LEAD BRASS
6	1	BODY	CAST NO LEAD BRASS
7	1	SADDLE NUT	CAST BRASS ASTM B62 ALLOY C83600
8	1	SNAP RING	PHOS BRONZE
9	1	RUBBER GASKET	NITRILE ASTM D2000

METER CONNX SIZE	A	B	FIP SIZE
5/8 x 3/4	1-11/16"	1-23/32"	3/4"
5/8 x 3/4 X 3/4	1-11/16"	1-23/32"	3/4"
5/8 x 3/4 x 1	1-11/16"	1-41/64"	1"
1	1-15/16"	2-1/32"	1"

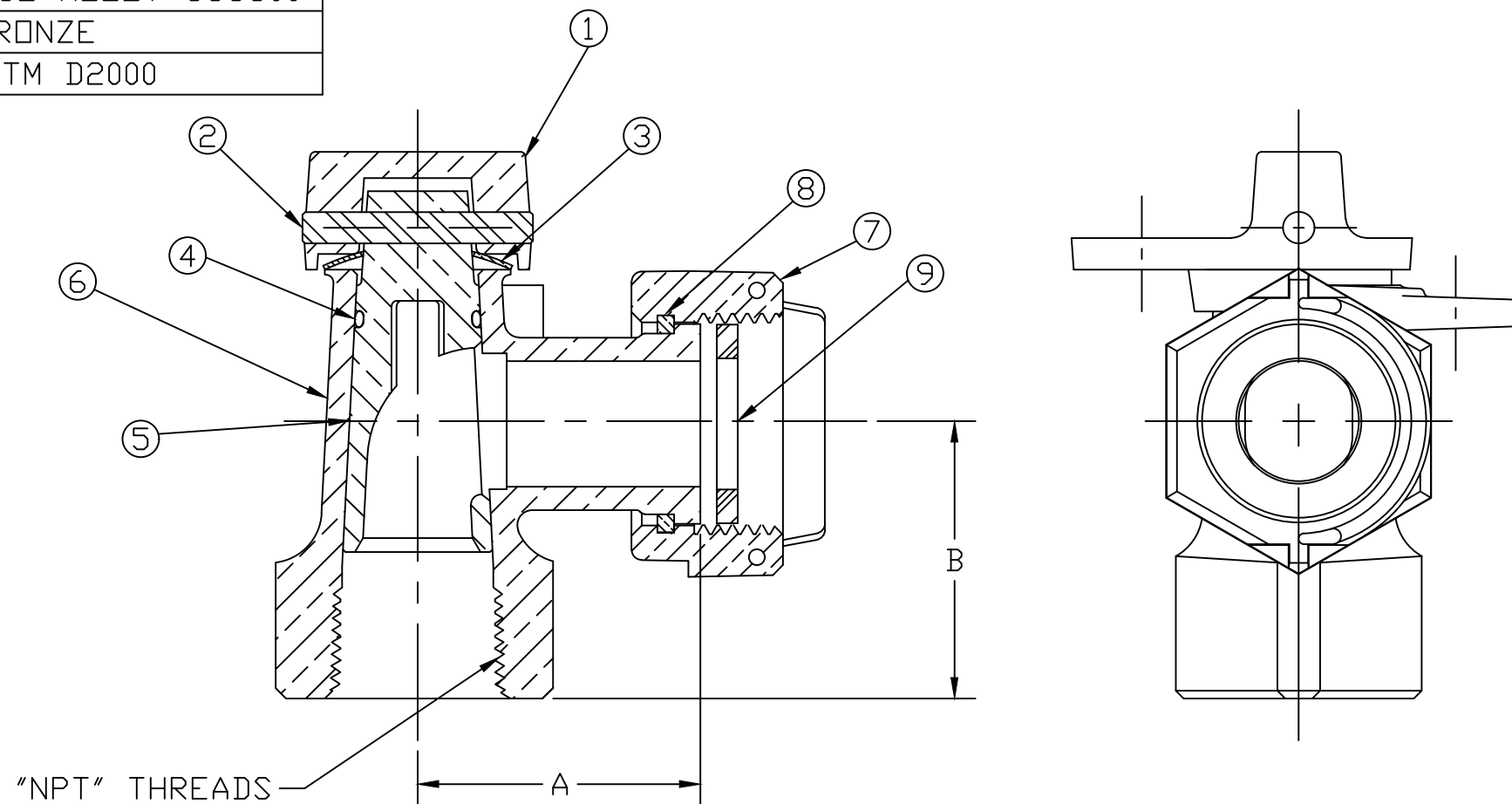

ALL WETTED PARTS ARE NO LEAD BRASS ALLOY

FILEPATH: PROD-ENG\MUELLER\ASYSUBMITTALS\H14265N

DRFTR: JGarvin 6/15/12

CHKR:

ENGR:

MGR:

BY: DATE:

STK No:

MAT'L:

DESCR:

INVERTED KEY NLB ANGLE METER STOP  
100 psi TEST/WP (MTR x FIP)

**MUELLER**

UNLESS OTHERWISE NOTED  
SURFACE PREPARATION:  
BREAK CORNER(S) ----- .000  
SURFACE FINISH -- XX RMS  
TOLERANCE(S):  
LINEAR ----- ± .000  
ANGULAR ----- ± 0°00'

THIRD ANGLE PROJECTION

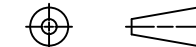

REF. No. SCALE  
NONE

TITLE TO AND OWNERSHIP OF THIS ENGINEERING DATA REMAINS IN Mueller Co. NO USE IS TO BE MADE OF THIS DATA EXCEPT AS SPECIFICALLY AUTHORIZED BY Mueller Co. ASSENT ON THE PART OF THE RECIPIENT TO THESE CONDITIONS IS PRESUMED.

REV	ECR	DESCRIPTION	DATE	BY	CHKR

PER EST NO: DXXXX EST FIN WT = 0.0000 lbs

DWG NUMBER  
H14265N  
442-MRKTG

DWG NUMBER  
H14265N