

No.	DESCRIPTION	MATERIAL
1	KEY CAP	CAST BRASS ASTM B62 ALLOY C83600
2	PIN	BRASS ASTM B16 ALLOY C36000
3	SPRING WASHER	PHOS BRONZE
4	O-RING	EPDM ASTM D2000
5	KEY	CAST LOW LEAD BRASS ALLOY
6	BODY	CAST LOW LEAD BRASS ALLOY
7	LOCK NUT	CAST BRASS ASTM B62 ALLOY C83600
8	RUBBER GASKET	NITRILE ASTM D2000

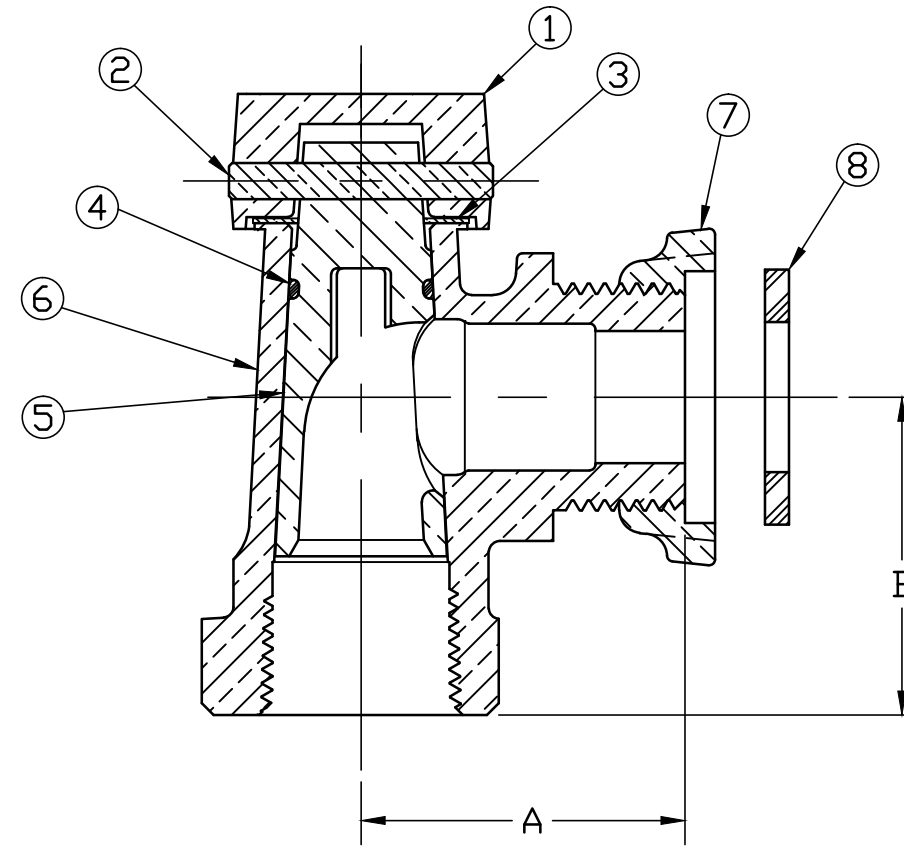

METER CONNX SIZE	A	B
5/8 x 3/4	1.688	1.656
5/8 x 3/4 x 3/4	1.688	1.656
1	2.062	2.031

ALL WETTED PARTS ARE LOW LEAD BRASS ALLOY

FILEPATH: PROD-ENG\MUELLER\ASYSUBMITTALS\H14278N

DWG NUMBER
H14278N
442-MRKTG

TITLE TO AND OWNERSHIP OF THIS ENGINEERING DATA REMAINS IN Mueller Co. NO USE IS TO BE MADE OF THIS DATA EXCEPT AS SPECIFICALLY AUTHORIZED BY Mueller Co. ASSENT ON THE PART OF THE RECIPIENT TO THESE CONDITIONS IS PRESUMED.

						DRFTR	RWB	1/11/13	Mueller Co.		
						CHKR					
						ENGR					
						MGR					
									UNLESS OTHERWISE NOTED	THIRD ANGLE PROJECTION	
									SURFACE PREPARATION:		
									BREAK CORNER(S) ----- .000		
									SURFACE FINISH -- XX RMS	REF. No.	SCALE
									TOLERANCE(S):		FULL
									LINEAR ----- ± .000		
									ANGULAR ----- ± 0°00'		
								STK No:			
								MAT'L:			
								DESCR.	ANGLE METER STOP - LLB	DWG NUMBER	
									FIP x IRON BAR	H14278N	
								PER EST NO: DXXXX	EST FIN WT = 0.0000 lbs		