

No.	DESCRIPTION	MATERIAL
1	BODY	CAST LOW LEAD BRASS ALLOY
2	KEY	CAST LOW LEAD BRASS ALLOY
3	KEY WASHER	CAST BRASS ASTM B62 ALLOY C83600
4	KEY NUT	CAST BRASS ASTM B62 ALLOY C83600
5	COPPER TUBE NUT	CAST BRASS ASTM B62 ALLOY C83600

SIZE	ØA	B	C	D	E
1/2"	.50	3.45	1.12	1.17	2.29
3/4"	.75	3.84	1.34	1.33	2.68
1"	1.00	4.52	1.41	1.44	2.85
1-1/4"	1.25	5.57	1.94	1.86	3.80
1-1/2"	1.50	6.36	2.27	2.22	4.49
2"	2.00	7.53	2.41	2.42	4.83

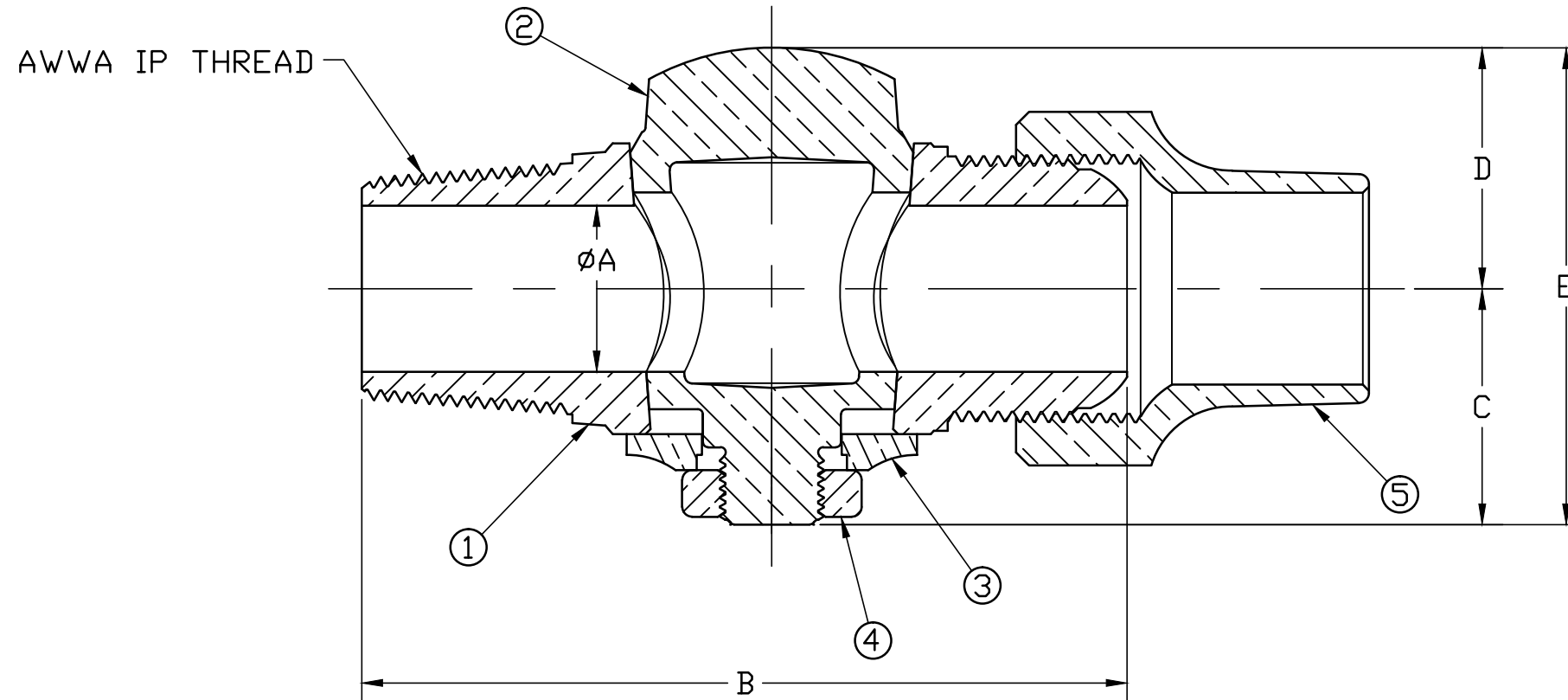

ALL WETTED PARTS ARE LOW LEAD BRASS ALLOY

FILEPATH: PROD-ENG\MUELLER\ASYSUBMITTALS\H15025N

						DRFTR	RWB	1/16/14	Mueller Co.		
						CHKR					
						ENGR					
						MGR					
									UNLESS OTHERWISE NOTED	THIRD ANGLE PROJECTION	
									SURFACE PREPARATION:		
									BREAK CORNER(S) ---- .000		
									SURFACE FINISH -- XX RMS	REF. No.	SCALE
									TOLERANCE(S):		FULL
									LINEAR ----- ± .000		
									ANGULAR ----- ± 0°00'		
									STK No:		
									MAT'L:		
									DESCR.	GROUND KEY LLB CORPORATION VALVE (AWWA "IP" x CS)	
										DWG NUMBER	H15025N

TITLE TO AND OWNERSHIP OF THIS ENGINEERING DATA REMAINS IN Mueller Co. NO USE IS TO BE MADE OF THIS DATA EXCEPT AS SPECIFICALLY AUTHORIZED BY Mueller Co. ASSENT ON THE PART OF THE RECIPIENT TO THESE CONDITIONS IS PRESUMED

REV	ECR	DESCRIPTION	DATE	BY	CHKR

PER EST NO: DXXXX EST FIN WT = 0.0000 lbs

DWG NUMBER
H15025N
442-MRKTG