

No.	DESCRIPTION	MATERIAL
1	BRANCH	CAST LOW LEAD BRASS ALLOY
2	TUBE NUT	CAST BRASS ASTM B62 ALLOY C83600

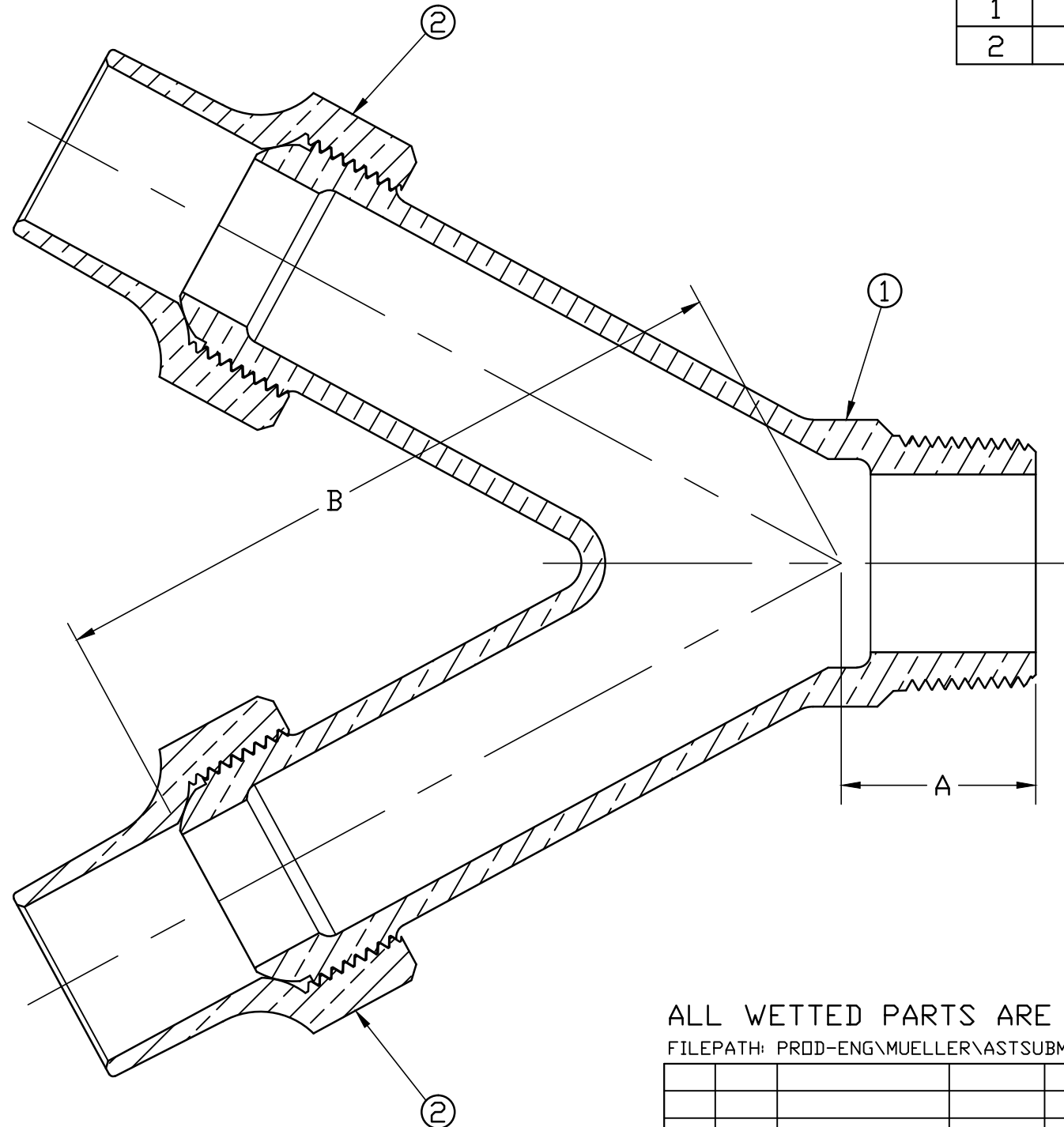

SIZE	A	B
3/4" x 1-1/2"	1.562	4.672
1" x 1-1/4"	1.281	4.672
1" x 1-1/2"	1.600	2.484
1" x 2"	1.062	2.484

ALL WETTED PARTS ARE LOW LEAD BRASS ALLOY

FILEPATH: PROD-ENG\MUELLER\ASTSUBMITTALS\H15341N

						DRFTR	RWB	3/1/18	<b>Mueller Co.</b>		
						CHKR					
						ENGR					
						MGR					
									UNLESS OTHERWISE NOTED	THIRD ANGLE PROJECTION	
									SURFACE PREPARATION:		
									BREAK CORNER(S) ---- .000		
									SURFACE FINISH -- XX RMS	REF. No.	SCALE
									TOLERANCE(S):		NONE
									LINEAR ----- ± .000		
									ANGULAR ----- ± 0°00'		
									STK No:		
									MAT'L:		
									DESCR.	LLB Y-BRANCH CONNECTION	DWG NUMBER
										(CS x MIP)	H15341N
									PER EST NO: DXXXX	EST FIN WT = 0.0000 lbs	

TITLE TO AND OWNERSHIP OF THIS ENGINEERING DATA REMAINS IN Mueller Co. NO USE IS TO BE MADE OF THIS DATA EXCEPT AS SPECIFICALLY AUTHORIZED BY Mueller Co. ASSENT ON THE PART OF THE RECIPIENT TO THESE CONDITIONS IS PRESUMED

DWG NUMBER  
H15341  
442-MRKTG