

ITEM	DESCRIPTION	MATERIAL DESCRIPTION
1	BRANCH	LEAD FREE BRASS ALLOY ASTM B584
2	CONNX NUT	CAST BRASS ALLOY ASTM B584
3	GASKET	ASTM D2000 (SBR)

SIZE	A	B	C
3/4" x 3/4" x 7-1/2"	7.50	1.61	3.65
1" x 3/4" x 6-1/2"	6.50	1.56	3.49
1" x 3/4" x 7-1/2"	7.50	1.56	3.49
1" x 3/4" x 13-1/2"	13.50	1.61	3.57
1-1/2" x 3/4" x 7-1/2"	7.50	1.49	3.38
1" x 1" x 7-1/2"	7.50	1.59	3.52
1-1/2" x 1" x 7-1/2"	7.50	1.61	3.50

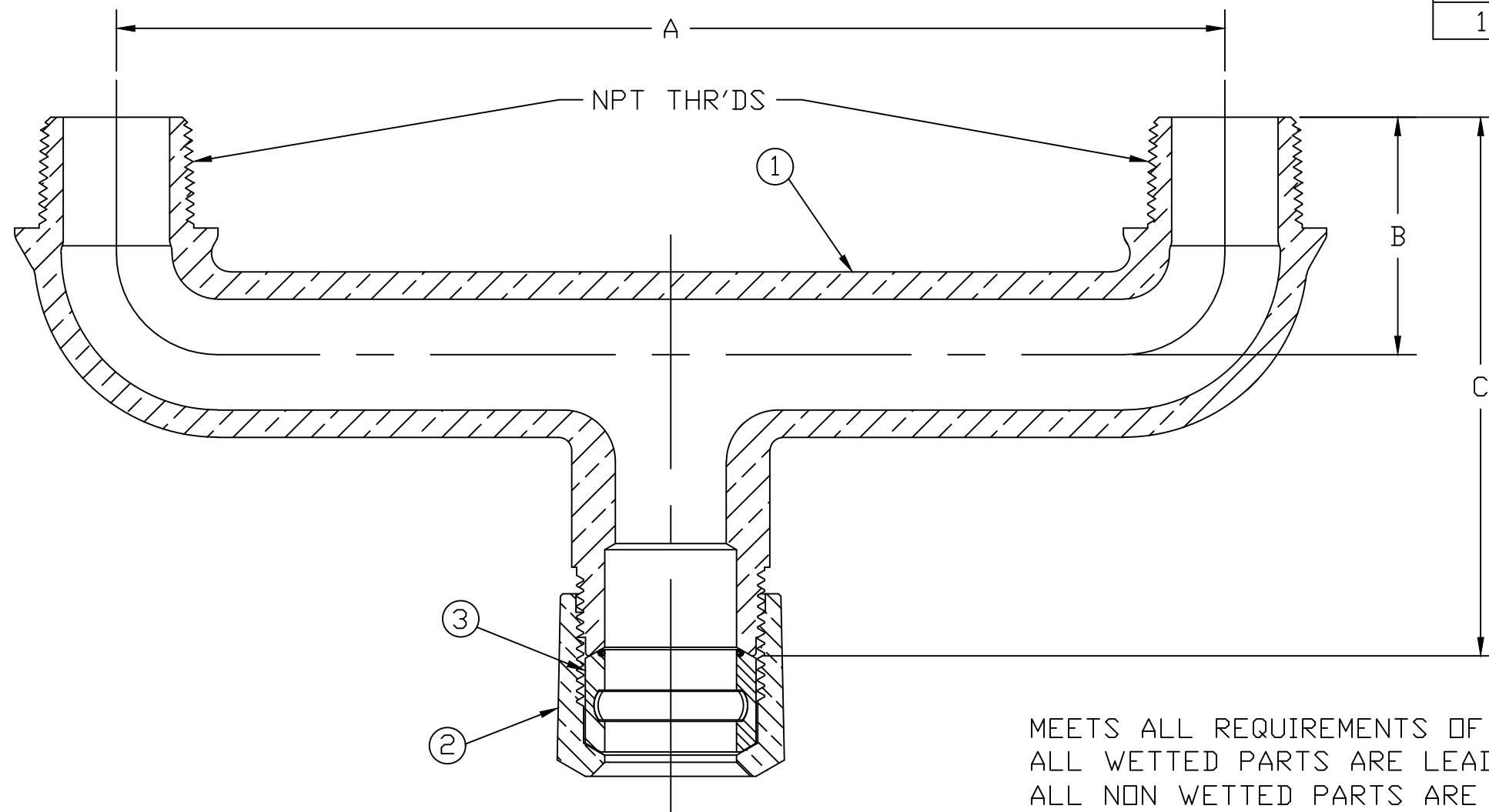

MEETS ALL REQUIREMENTS OF AWWA C800  
 ALL WETTED PARTS ARE LEAD FREE BRASS ALLOY C89833/C87850  
 ALL NON WETTED PARTS ARE BRASS ALLOY C83600/C87850

DWG NUMBER  
H15363N

TITLE TO AND OWNERSHIP OF THIS ENGINEERING  
 DATA REMAINS IN Mueller Co. NO USE IS TO BE  
 MADE OF THIS DATA EXCEPT AS SPECIFICALLY  
 AUTHORIZED BY Mueller Co. ASSENT ON THE PART  
 OF THE RECIPIENT TO THESE CONDITIONS IS PRESUMED

DRFTR	AD	03/06/23	<b>MUELLER</b>	
CHKR				
ENGR			UNLESS OTHERWISE NOTED SURFACE PREPARATION: BREAK CORNER(S) ---- .000 SURFACE FINISH -- XX RMS	THIRD ANGLE PROJECTION
MGR				REF. No.
	BY	DATE	LINEAR ----- ± .000	NONE
			ANGULAR ----- ± 0°00'	
STK No:			MAT'L:	
DESCR.	U-BRANCH CONNECTION (110 CTS x MIP)			DWG NUMBER H15363N