

No.	DESCRIPTION	MATERIAL
1	SPUD	NO LEAD BRASS ALLOY ASTM B584
2	CS NUT	CAST BRASS ASTM B62 ALLOY C83600

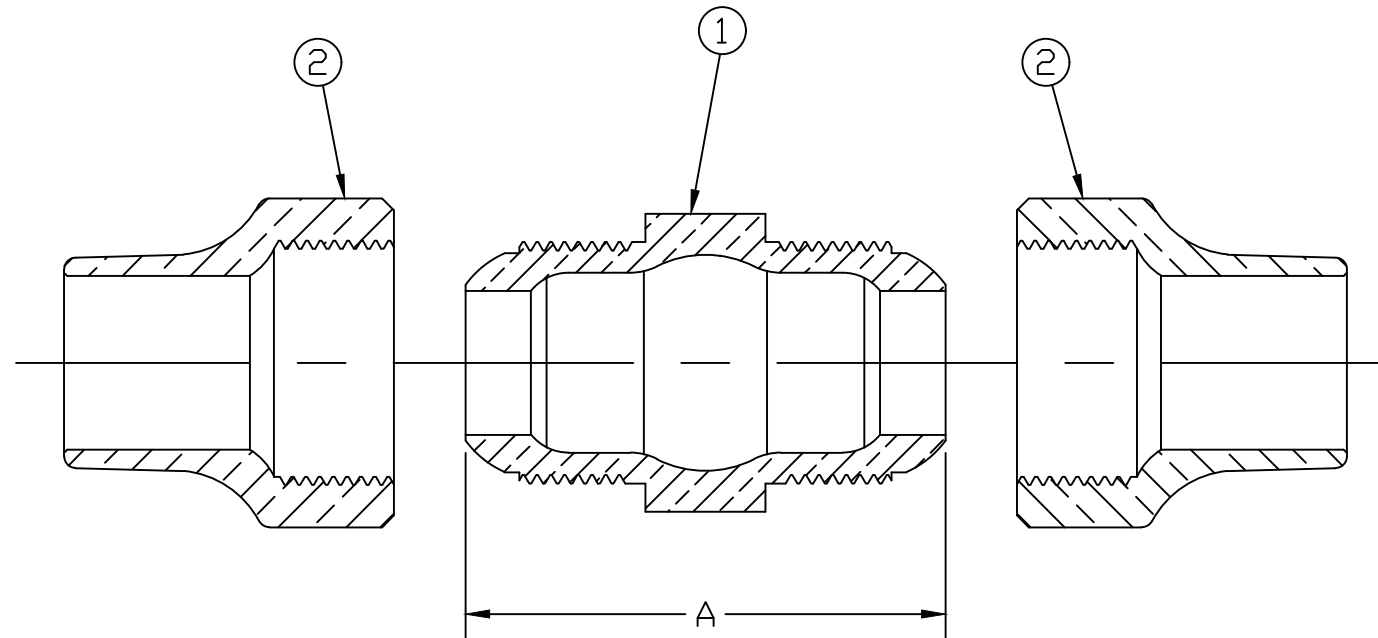

SIZE	A
1/2	2.190
5/8	2.375
5/8x1/2	2.375
5/8x3/4	2.500
3/4	2.500
3/4x1/2	2.375
3/4 x 1	2.938
1	2.938
1-1/4	3.688
1-1/4x1	3.688
1-1/2	4.062
2	4.892

MEETS ALL REQUIREMENTS OF AWWA C800
 ALL WETTED PARTS ARE LOW LEAD BRASS ALLOY C89833 OR C87850

DWG NUMBER
H15400N

TITLE TO AND OWNERSHIP OF THIS ENGINEERING
 DATA REMAINS IN Mueller Co. NO USE IS TO BE
 MADE OF THIS DATA EXCEPT AS SPECIFICALLY
 AUTHORIZED BY Mueller Co. ASSENT ON THE PART
 OF THE RECIPIENT TO THESE CONDITIONS IS PRESUMED

						DRFTR	JGarvin	2/10/12	MUELLER	THIRD ANGLE PROJECTION
						CHKR				
						ENGR				
						MGR				
									UNLESS OTHERWISE NOTED	
									SURFACE PREPARATION:	
									BREAK CORNER(S) ----- .000	REF. No.
									SURFACE FINISH -- 000 RMS	SCALE
									TOLERANCE(S):	NONE
									LINEAR ----- ± .000	
									ANGULAR ----- ± 0°00'	
								STK No:		
								MAT'L:		
								DESCR.	NLB COPPER COUPLING (CS x CS)	DWG NUMBER H15400N
								PER EST NO: DXXXX	EST FIN WT = 0.0000 lbs	