

No.	DESCRIPTION	MATERIAL
1	SPUD	CAST NO LEAD BRASS ALLOY

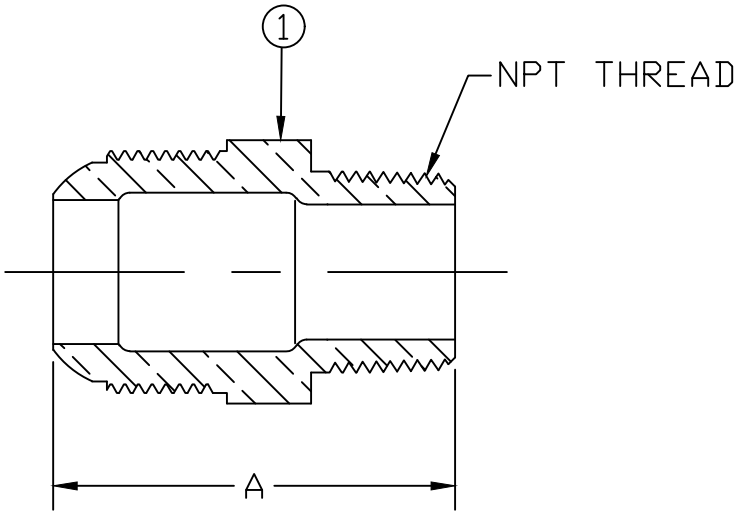

SIZE	A	NPT
1/2"	2.03	1/2"
1/2" x 3/4"	2.09	3/4"
5/8" x 1/2"	2.03	1/2"
3/4"	2.12	3/4"
3/4" x 1/2"	2.03	1/2"
3/4" x 1"	2.38	1"
1"	2.66	1"
1" x 3/4"	2.53	3/4"
1" x 2"	2.84	2"
1-1/4"	3.09	1-1/4"
1-1/2"	3.34	1-1/2"
2"	3.98	2"

ALL WETTED PARTS ARE NO LEAD BRASS ALLOY

FILEPATH: PROD-ENG\MUELLER\ASYSUBMITTALS\H1542517N

						DRFTR	RWB	4/2/18	MUELLER	UNLESS OTHERWISE NOTED THIRD ANGLE PROJECTION SURFACE PREPARATION: BREAK CORNER(S) ---- .000 SURFACE FINISH -- XX RMS TOLERANCE(S): LINEAR ----- ± .000 ANGULAR ----- ± 0°00'					
						CHKR						REF. No.	SCALE FULL		
						ENGR									
						MGR									
							BY	DATE	STK No:						
									MAT'L:						
									DESCR.	NLB STRAIGHT SERVICE FITTING LESS COPPER TUB NUT (CS x MIP)	DWG NUMBER H1542517N				
									REV	ECR	DESCRIPTION	DATE	BY	CHKR	PER EST NO: DXXXX EST FIN WT = 0.0000 lbs

TITLE TO AND OWNERSHIP OF THIS ENGINEERING DATA REMAINS IN Mueller Co. NO USE IS TO BE MADE OF THIS DATA EXCEPT AS SPECIFICALLY AUTHORIZED BY Mueller Co. ASSENT ON THE PART OF THE RECIPIENT TO THESE CONDITIONS IS PRESUMED

DWG NUMBER
H1542517N
442-MRKTG