

No.	DESCRIPTION	MATERIAL
1	SPUD	LEAD FREE BRASS ALLOY ASTM B584
2	COPPER TUBE NUT	CAST BRASS ALLOY ASTM B584

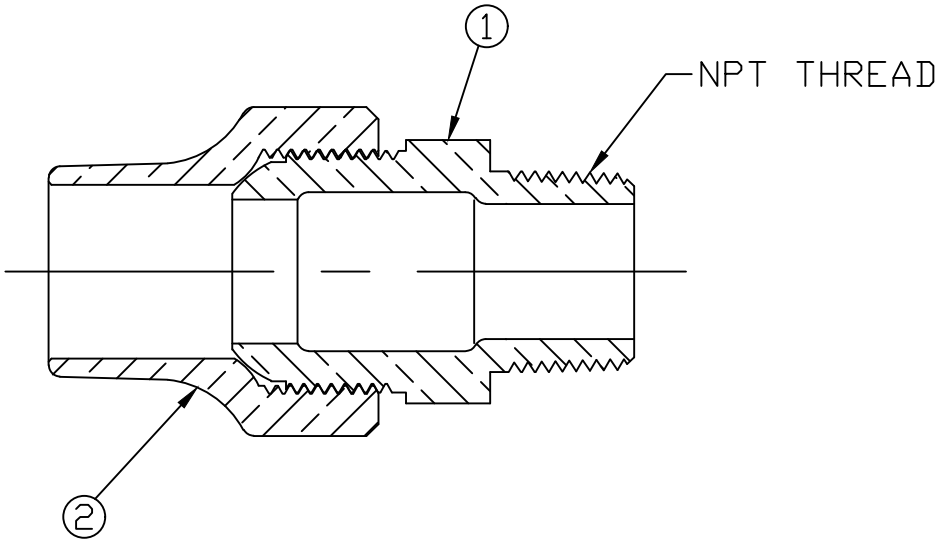

SIZE	A	NPT
1/2"	2.03	1/2"
1/2" x 3/4"	2.09	3/4"
5/8" x 1/2"	2.03	1/2"
3/4"	2.12	3/4"
3/4" x 1/2"	2.03	1/2"
3/4" x 1"	2.38	1"
1"	2.66	1"
1" x 3/4"	2.53	3/4"
1" x 2"	2.84	2"
1-1/4"	3.09	1-1/4"
1-1/2"	3.34	1-1/2"
2"	3.98	2"

MEETS ALL REQUIREMENTS OF AWWA C800  
 ALL WETTED PARTS ARE LEAD FREE BRASS ALLOY C89833/C87850  
 ALL NON WETTED PARTS ARE BRASS ALLOY C83600/C87850

DWG NUMBER  
H15425N

TITLE TO AND OWNERSHIP OF THIS ENGINEERING  
 DATA REMAINS IN Mueller Co. NO USE IS TO BE  
 MADE OF THIS DATA EXCEPT AS SPECIFICALLY  
 AUTHORIZED BY Mueller Co. ASSENT ON THE PART  
 OF THE RECIPIENT TO THESE CONDITIONS IS PRESUMED

DRFTR	AD	03/02/23	<b>MUELLER</b>		
CHKR					
ENGR			UNLESS OTHERWISE NOTED SURFACE PREPARATION: BREAK CORNER(S) ---- .000 SURFACE FINISH -- XX RMS	THIRD ANGLE PROJECTION	
MGR				REF. No.	SCALE
	BY	DATE	TOLERANCE(S): LINEAR ----- ± .000 ANGULAR ----- ± 0°00'		FULL
STK No:			MAT'L:		
DESCR.			STRAIGHT SERVICE FITTING (CS x MIP)		
			DWG NUMBER H15425N		