

No.	DESCRIPTION	MATERIAL
1	SPUD	LEAD FREE BRASS ALLOY ASTM B584
2	FIBER GASKET	ASTM D170 VULCANIZED FIBER
3	CONN. NUT	CAST BRASS ALLOY ASTM B584
3	CTS GSKT SUB	SBR D2000 - GSKT 410ss - BAND

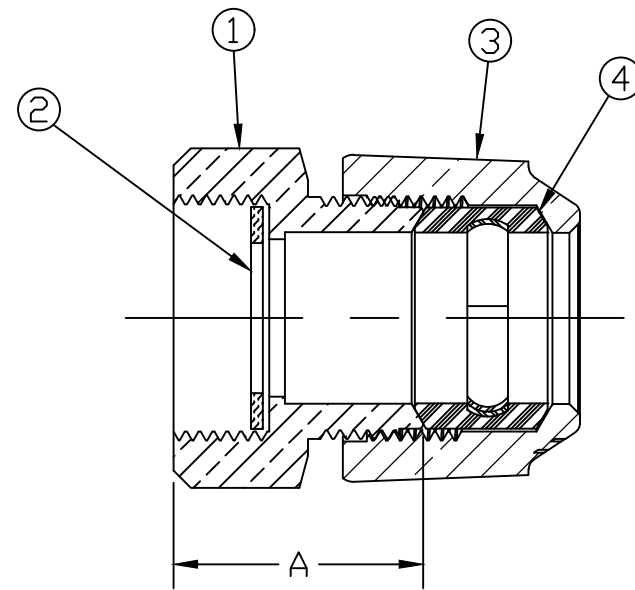

SIZE	A
1/2" x 3/4"	1.58
5/8" x 3/4"	1.58
3/4"	1.30
1"	1.56

MEETS ALL REQUIREMENTS OF AWWA C800
 ALL WETTED PARTS ARE LEAD FREE BRASS ALLOY C89833/C87850
 ALL NON WETTED PARTS ARE BRASS ALLOY C83600/C87850

DWG NUMBER
H15481N

TITLE TO AND OWNERSHIP OF THIS ENGINEERING
 DATA REMAINS IN Mueller Co. NO USE IS TO BE
 MADE OF THIS DATA EXCEPT AS SPECIFICALLY
 AUTHORIZED BY Mueller Co. ASSENT ON THE PART
 OF THE RECIPIENT TO THESE CONDITIONS IS PRESUMED

DRFTR	AD	02/21/23	MUELLER	
CHKR				
ENGR				
MGR				
			UNLESS OTHERWISE NOTED	THIRD ANGLE PROJECTION
			SURFACE PREPARATION:	
			BREAK CORNER(S) ---- .000	
			SURFACE FINISH -- XX RMS	REF. No.
	BY	DATE	TOLERANCE(S):	SCALE
			LINEAR ----- ± .000	FULL
			ANGULAR ----- ± 0°00'	
STK No:			MAT'L:	
DESCR.	CORPORATION STOP COUPLING (I/S MUELLER x 110 CTS)			DWG NUMBER H15481N