

No.	DESCRIPTION	MATERIAL
1	GASKET	FIBER ASTM D710
2	TUBE NUT	CAST BRASS ALLOY ASTM B584
3	SPUD	LEAD FREE BRASS ALLOY ASTM B584

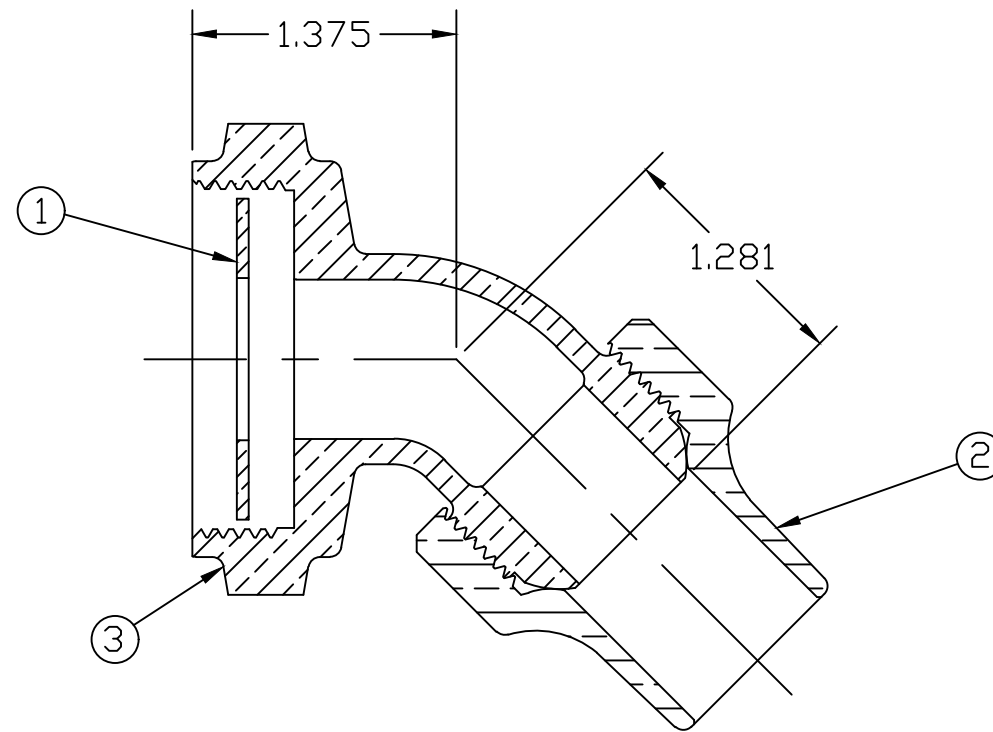

SIZE	A	B
5/8" x 3/4"	1.38	1.28
3/4"	1.38	1.28
1"	1.50	1.44

MEETS ALL REQUIREMENTS OF AWWA C800  
 ALL WETTED PARTS ARE LEAD FREE BRASS ALLOY C89833/C87850  
 ALL NON WETTED PARTS ARE BRASS ALLOY C83600/C87850

DWG NUMBER  
H15515N

TITLE TO AND OWNERSHIP OF THIS ENGINEERING  
 DATA REMAINS IN Mueller Co. NO USE IS TO BE  
 MADE OF THIS DATA EXCEPT AS SPECIFICALLY  
 AUTHORIZED BY Mueller Co. ASSENT ON THE PART  
 OF THE RECIPIENT TO THESE CONDITIONS IS PRESUMED

DRFTR	AD	03/02/23	<b>MUELLER</b>	
CHKR				
ENGR			UNLESS OTHERWISE NOTED	THIRD ANGLE PROJECTION
MGR				SURFACE PREPARATION: BREAK CORNER(S) ----- .000 SURFACE FINISH -- 000 RMS TOLERANCE(S): LINEAR ----- ± .000 ANGULAR ----- ± 0°00'
	BY	DATE	REF. No.	SCALE
STK No:				NONE
MAT'L:				
DESCR.	1/8 BEND CORP. STOP COUPLING (INSIDE XS LEAD x CS OUTLET)			DWG NUMBER H15515