

IMPROVED FIRE HYDRANT

PARTS

IMPROVED HYDRANT WITH
BRASS SAFETY STEM COUPLING

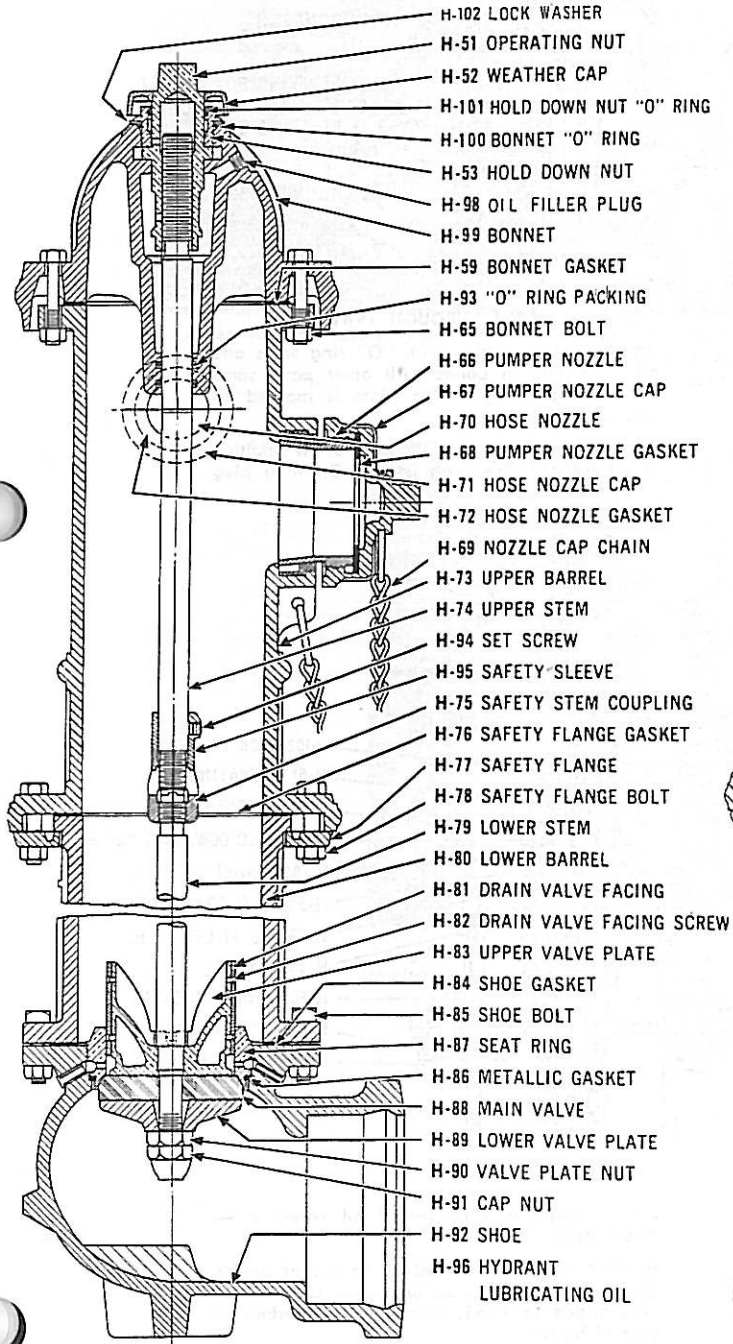

IMPROVED HYDRANT WITH
STEEL SAFETY STEM COUPLING

