

MUELLER

P-2361 RESILIENT WEDGE GATE VALVE

NRS – PIV: 14" – 24"/DN350 – DN600

PRODUCT FEATURES

- Non-Rising Stem (NRS), Post Indicator Valve (PIV).
- Ductile Iron Body, Bonnet, and Post Indicator Flange.
- Mueller Pro-Gard® Fusion Bonded Epoxy Coating inside and out cover all cast surfaces – 10 mils (250 µm) nominal. Meets requirements of AWWA/ANSI C550.
- Meets requirements of AWWA/ANSI C515 and is certified to ANSI/NSF 61 & 372.
- Ductile Iron wedge, symmetrical & fully encapsulated with molded rubber; no exposed iron.
- Polymer cap bearing on wedge guides resist wear and provide easy operation.
- Three stem O-rings seal in lubricant – two above thrust collar, one below.
- Polymer anti-friction washers – one above and one below thrust collar reduces operating torque.
- Bi-directional flow.
- 10-year limited warranty.
- Pressure rating: 14" & 16"/DN350 & DN400 AWWA/UL/FM rating 250 psig/17 barg; 18" – 24"/DN450 – DN600 AWWA rating 250 psig/17 barg, UL rating 175 psig/12 barg, FM Approved rating 250 psig/17 barg.
- Flange End drilling meets: ANSI B16.1 Class 125 Flat Face and ANSI B16.42 Class 150 Flat Face. 14" & 16"/DN350 & DN400 optional PN10, PN16 drilling. Mechanical Joint also available.

18"/DN450 SHOWN



PARTS LIST

ID	PART NAME	MATERIAL
1	Cap Screw	316 Stainless Steel
2	Wrench Nut	Cast Iron ASTM A126 CL B (See Note 3)
3	Stem	Bronze ASTM B138 (See Note 2)
4	Stuffing Box	Ductile Iron ASTM 536
5	Stuffing Box Bolts/Nuts	316 Stainless Steel
6	O-Ring	ASTM D2000 (See Note 4)
7	O-Ring	ASTM D2000 (See Note 4)
8	Anti-Friction Washer	Brass
9	Bonnet	Ductile Iron ASTM A536
10	Bonnet Bolts/Nuts	316 Stainless Steel
11	Bonnet O-Ring	ASTM D2000 (See Note 4)
12	Wedge Nut	Bronze ASTM B62
13	Wedge	(See Note 1)
14	Guide Cap	Acetal
15	Body	Ductile Iron ASTM A536
16	Stuffing Box Insert	Carbon Steel ASTM A36
17	Bonnet Bushing	Bronze ASTM B62
18	Eyebolt	Galvanized Steel
19	Nut Steel	316 Stainless Steel

Notes:

1. Rubber-encapsulated Ductile Iron Wedge; 14" & 16"/DN350 & DN400 Rubber – SBR ASTM D2000, 18" – 24"/DN450 – DN600 Rubber – EPDM ASTM D2000, Ductile Iron – ASTM A536 Grade 65-45 (min. strength).
2. 14" & 16"/DN350 & DN400 Manganese Bronze ASTM B138 C67600, 18" – 24"/DN450 – DN600 Manganese Bronze ASTM B584 C86400.
3. Manufacturer's option to upgrade to Ductile Iron ASTM A536.
4. 14" & 16"/DN350 & DN400 Nitrile, 18" – 24"/DN450 – DN600 EPDM.

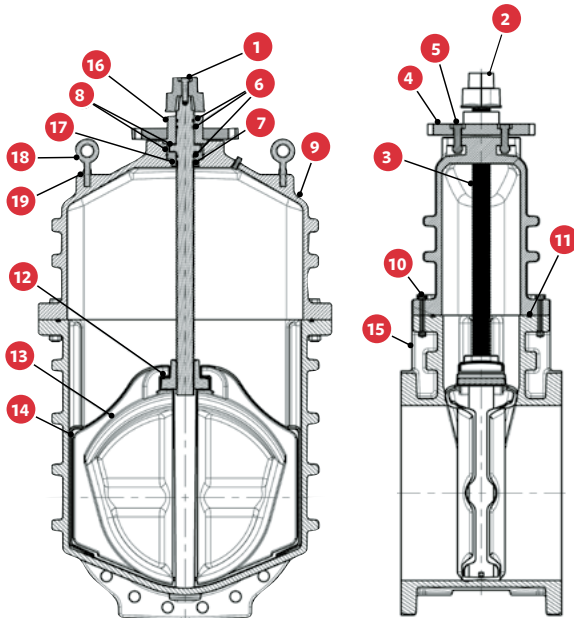

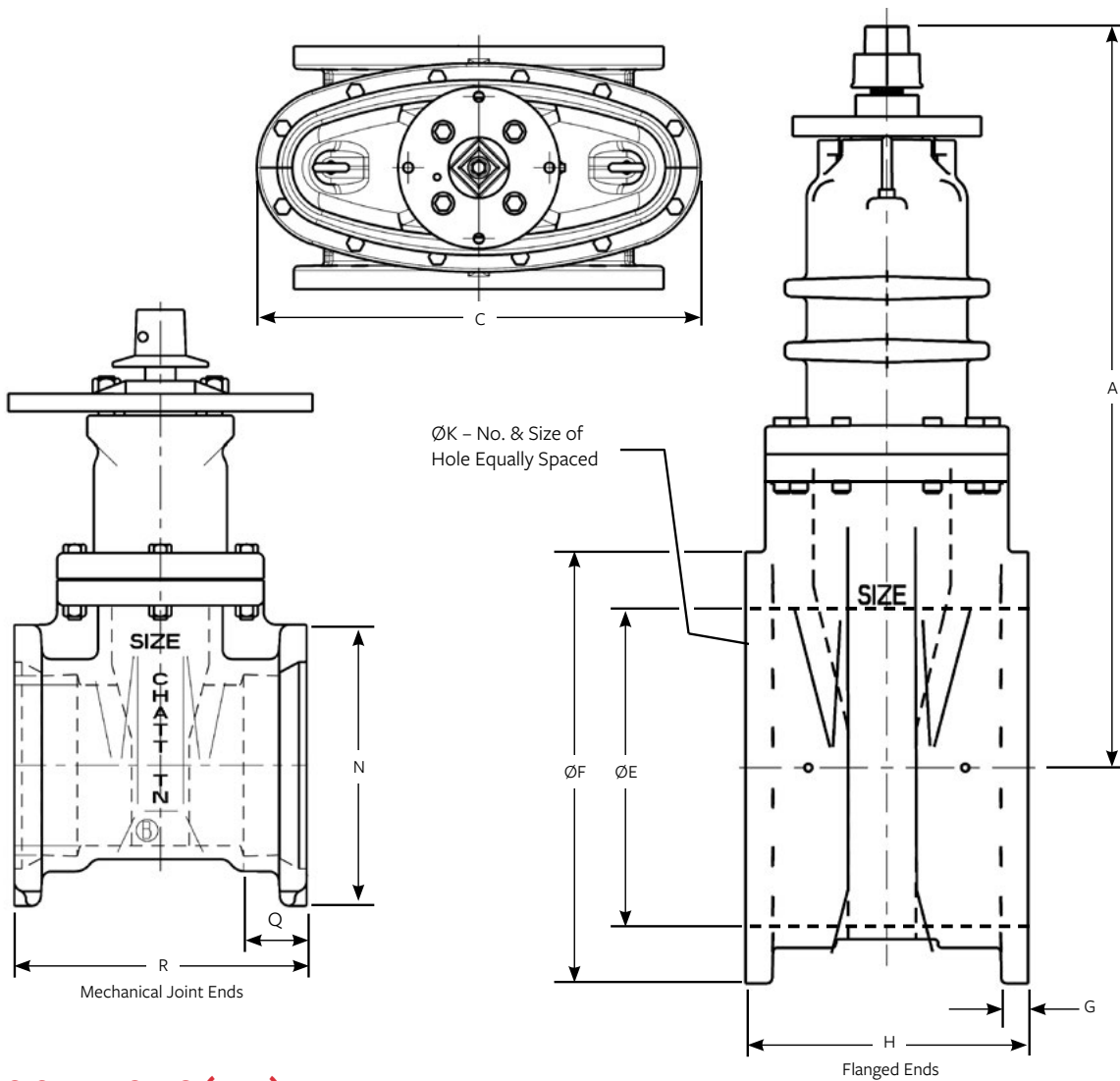

DIMENSION - INCHES (MM)

VALVE SIZE	A	C	ØE	ØF	G	H	NO.-ØK	R	N	Q
14"/DN350	32.75 (832)	24.92 (633)	14.38 (365)	21.00 (533)	1.42 (36)	15.06 (383)	12 - 1.12 (28)	19.88 (505)	20.25 (514)	3.50 (89)
16"/DN400	37.88 (962)	26.58 (675)	16.00 (400)	23.50 (597)	1.05 (27)	16.06 (408)	16 - 1.12 (28)	19.75 (502)	22.56 (573)	3.50 (89)
18"/DN450	44.19 (1122)	30.50 (775)	18.38 (467)	25.00 (635)	1.05 (27)	17.00 (432)	16 - 1.25 (32)	21.00 (533)	24.87 (632)	3.50 (89)
20"/DN500	48.25 (1225)	33.75 (857)	20.38 (518)	27.50 (698)	1.78 (45)	18.00 (450)	20 - 1.25 (32)	21.50 (546)	27.24 (692)	3.50 (89)
24"/DN600	53.88 (1369)	39.50 (1003)	24.38 (619)	32.00 (800)	1.25 (32)	20.00 (500)	20 - 1.38 (35)	23.50 (597)	31.88 (810)	3.50 (89)

WEIGHT - LB. (KG)

Valve Size	14"/DN350	16"/DN400	18"/DN450	20"/DN500	24"/DN600
Flanged	659 (299)	841 (381)	1298 (589)	1640 (744)	2488 (1129)
MJ*	650 (295)	931 (422)	1298 (589)	1640 (744)	2423 (1099)

*Weights approximate, MJ less accessories

For more information about us or to view our full line of products, please visit www.mueller-international.com or call International Customer Service at:

UK: +44.1438.487410 Dubai: +971.4.214.6640 Singapore: +65.6816.3088 USA: +1.800.423.1323 | international@muellerwp.com

Mueller refers to one or more of Mueller Water Products, Inc. a Delaware corporation ("MWP"), and its subsidiaries. MWP and each of its subsidiaries are legally separate and independent entities when providing products and services. MWP does not provide products or services to third parties. MWP and each of its subsidiaries are liable only for their own acts and omissions and not those of each other. MWP brands include Mueller®, Echologics®, Hydro Gate®, Hydro-Guard®, Jones®, Krausz®, MiNet®, Milliken®, Pratt®, Pratt Industrial®, Singer®, and U.S. Pipe Valve & Hydrant. Please see muellerwp.com/brands to learn more.

© 2020 Mueller Water Products, Inc. All Rights Reserved. The trademarks, logos and service marks displayed in this document are the property of Mueller Water Products, Inc., its affiliates or other third parties. Products above marked with a section symbol (§) are subject to patents or patent applications. For details visit www.wppat.com.

F 12930 3/20

MUELLER