

MUELLER

P-2362 RESILIENT WEDGE GATE VALVE

NRS – PIV: 4" – 12"/DN100 – DN300

PRODUCT FEATURES

- Non-Rising Stem (NRS), Post Indicator Valve (PIV).
- Ductile Iron Body, Bonnet and Post Indicator Flange.
- Mueller Pro-Gard® Fusion Bonded Epoxy Coating inside and out cover all cast surfaces – 10 mils (250 µm) nominal. Meets requirements of AWWA/ANSI C550.
- Meets requirements of AWWA/ANSI C509 and is certified to ANSI/NSF 61 & 372.
- Ductile Iron wedge, symmetrical & fully encapsulated with molded rubber; no exposed iron.
- Polymer cap bearing on wedge guides resist wear and provide easy operation.
- Three stem O-rings seal in lubricant – two above thrust collar, one below.
- Polymer anti-friction washers – one above and one below thrust collar reduce operating torque.
- Bi-directional flow.
- 10-year limited warranty.
- Working Pressure: 350 psig/24 barg; Test Pressure: 700 psig/48 barg.
- UL 262 listed; FM 1120/1130 approved.
- Flange End drilling meets: ANSI B16.1, Class 125 and ANSI B16.42, Class 150 Flat Face. Optional PN10, PN16 drilling. Mechanical Joint also available.

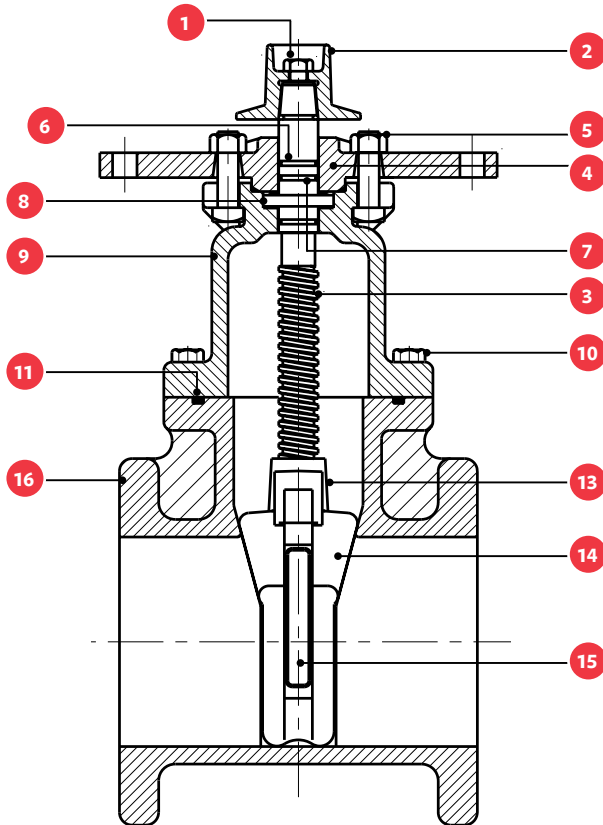

PARTS LIST

ID	PART NAME	MATERIAL
1	Cap Screw	316 Stainless Steel (See Note 2)
2	Operating Nut	Ductile Iron ASTM A536
3	Stem	Bronze ASTM B138 (C67600)
4	Stuffing Box	Ductile Iron ASTM A536
5	Stuffing Box Bolts/Nuts	316 Stainless Steel (See Note 2)
6	O-Ring	NBR ASTM D2000
7	O-Ring	NBR ASTM D2000
8	Anti-Friction Washer	Acetal
9	Bonnet	Ductile Iron ASTM A536
10	Bonnet Bolts/Nuts	316 Stainless Steel (See Note 2)
11	Bonnet Gasket (O-Ring)	NBR ASTM D2000
13	Wedge Nut	Bronze ASTM B584
14	Wedge	(See Note 1)
15	Guide Cap	Acetal
16	Body	Ductile Iron ASTM A536

NOTES:

1. Rubber-encapsulated Ductile Iron Disc, Rubber – SBR ASTM D2000, Ductile Iron ASTM A536.
2. Bonnet Bolts, Cap Screw and Stuffing Box Bolts – ASTM F593 Group 2-CW; Nuts – ASTM F594 Group 2-CW.

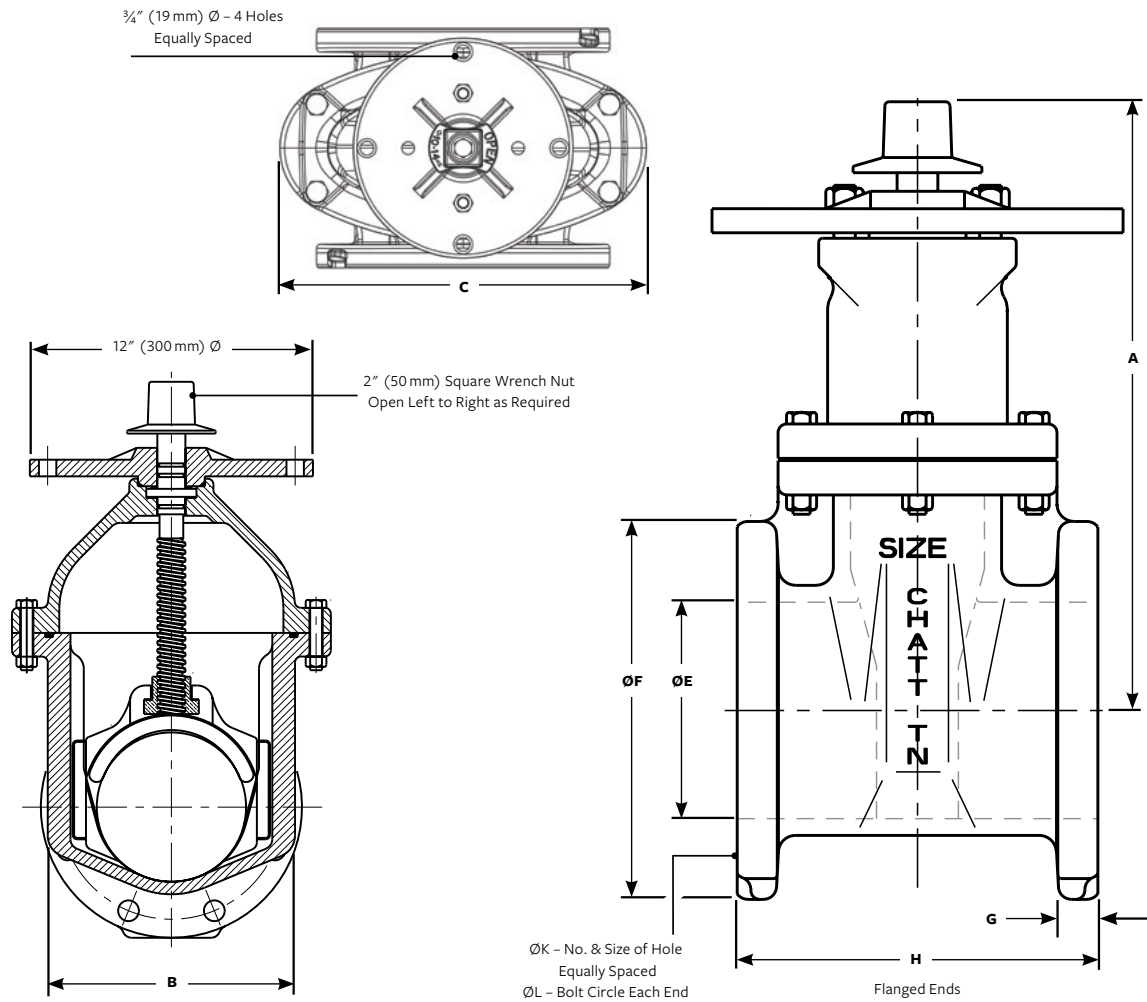

DIMENSIONS – INCHES (MM)

VALVE SIZE	A	B	C	ØE	ØF	G	H	NO. - ØK	ØL	TURNS TO OPEN
4"/DN100	14.19 (360)	7.75 (210)	10.79 (274)	4.30 (109)	9.00 (229)	1.00 (25)	9.00 (229)	8 - 0.75 (19)	7.50 (191)	14
6"/DN150	18.00 (457)	9.97 (267)	13.50 (343)	6.30 (160)	11.00 (279)	1.06 (27)	10.50 (267)	8 - 0.88 (22)	9.50 (241)	20.5
8"/DN200	21.50 (546)	12.60 (336)	16.36 (416)	8.30 (211)	13.50 (343)	1.19 (30)	11.50 (292)	8 - 0.88 (22)	11.75 (298)	26.5
10"/DN250	25.50 (648)	16.48 (419)	19.99 (508)	10.30 (262)	16.00 (406)	1.25 (32)	13.00 (330)	12 - 1.00 (25)	14.25 (362)	33
12"/DN300	28.62 (727)	16.83 (427)	21.00 (533)	12.30 (312)	19.00 (483)	1.31 (33)	14.00 (356)	12 - 1.00 (25)	17.00 (432)	38.5

WEIGHT – LB (KG)

Valve Size	4"/DN100	6"/DN150	8"/DN200	10"/DN250	12"/DN300
Flanged	112 (51)	168 (76)	268 (122)	409 (186)	540 (245)

For more information about us or to view our full line of products, please visit www.mueller-international.com or call International Customer Service at:

UK: +44.1438.487410 Dubai: +971.4.214.6640 Singapore: +65.6816.3088 USA: +1.800.423.1323 | international@muellerwp.com

Mueller refers to one or more of Mueller Water Products, Inc. a Delaware corporation ("MWP"), and its subsidiaries. MWP and each of its subsidiaries are legally separate and independent entities when providing products and services. MWP does not provide products or services to third parties. MWP and each of its subsidiaries are liable only for their own acts and omissions and not those of each other. MWP brands include Mueller®, Echologics®, Hydro Gate®, Hydro-Guard®, Jones®, Krausz®, MiNet®, Milliken®, Pratt®, Pratt Industrial®, Singer®, and U.S. Pipe Valve & Hydrant. Please see muellerwp.com/brands to learn more.

© 2020 Mueller Water Products, Inc. All Rights Reserved. The trademarks, logos and service marks displayed in this document are the property of Mueller Water Products, Inc., its affiliates or other third parties. Products above marked with a section symbol (§) are subject to patents or patent applications. For details visit www.mwppat.com.