

MUELLER

P-2361+ RESILIENT WEDGE GATE VALVE

PIV – PLUS: 14" – 24"/DN350 – DN600

PRODUCT FEATURES

- Post Indicator Valve (PIV), Standard-PLUS (+) Gate Valve
- Ductile Iron Body and Bonnet, Ductile Iron Post Indicator Flange
- Mueller Pro-Gard® 2-Pass Fusion Bonded Epoxy Coating covers all cast surfaces inside and out – 10 mils (250 µm) minimum. Meets requirements of AWWA/ANSI C550.
- Meets requirements of AWWA/ANSI C515 and is certified to ANSI/NSF 61 & 372
- Ductile Iron Wedge, symmetrical and fully encapsulated with molded EPDM rubber; no exposed iron

18"/DN450 shown

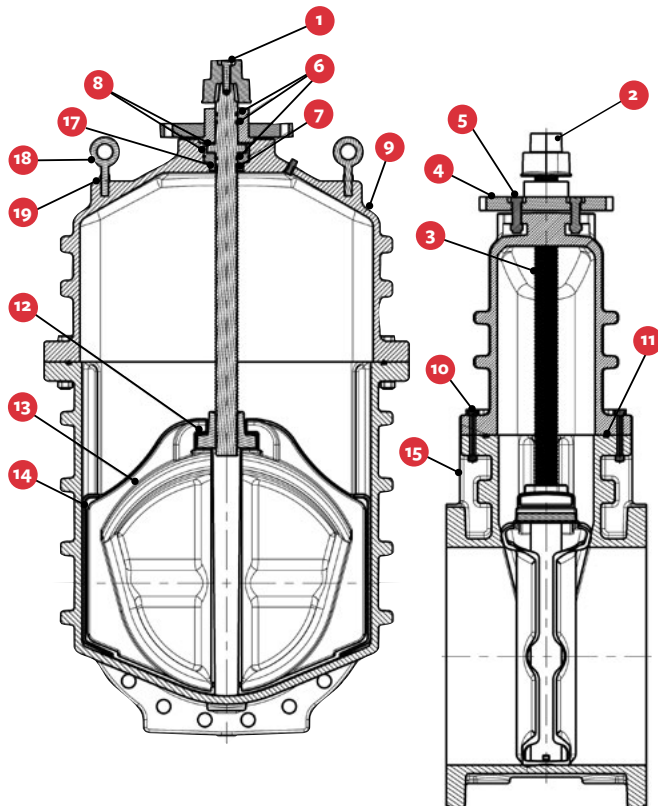

PARTS LIST

ID	PART NAME	MATERIAL
1	Cap Screw	316 Stainless Steel (See Note 2)
2	Wrench Nut	Cast Iron ASTM A126 CL B
3	Stem	Silicon Bronze (See Note 3)
4	Stuffing Box	Ductile Iron ASTM 536
5	Stuffing Box Bolts/Nuts	316 Stainless Steel (See Note 2)
6	O-Ring	EPDM ASTM D2000
7	O-Ring	EPDM ASTM D2000
8	Anti-Friction Washer	Acetal
9	Bonnet	Ductile Iron ASTM A536
10	Bonnet Bolts/Nuts	316 Stainless Steel (See Note 2)
11	Bonnet Gasket (O-Ring)	EPDM ASTM D2000
12	Disc Nut	Bronze ASTM B62
13	Disc	(See Note 1)
14	Guide Cap	Acetal
15	Body	Ductile Iron ASTM A536
17	Bonnet Bushing	Bronze ASTM B62
18	Eyebolt	Galvanized Steel
19	Nut	Steel ASTM A307 (See Note 2)

Notes:

1. 14" – 24"/DN350 – DN600 Rubber-encapsulated Ductile Iron Disc, Rubber – EPDM ASTM D2000, Ductile Iron – ASTM A536 Grade 65-45-12 (minimum strength).
2. Bolts – 316 Stainless Steel ASTM F593 Group 2-CW. Nuts – 316 Stainless Steel ASTM F594 Group 2-CW.
3. 14" & 16"/DN350 & DN400 ASTM B98 (C66100), 18" – 24"/DN450 – DN600 ASTM B763 (C99400).

PRODUCT FEATURES CONT.

- Polymer cap bearing on wedge guides
- Everdur Bronze Stem
- 316 Bolts, Nuts and Washers
- Three stem O-rings seal in lubricant – two above thrust collar, one below
- Polymer anti-friction washers – one above and one below thrust collar reduce operating torque
- 10-year limited warranty
- Pressure rating: 14" & 16"/DN350 & DN400 AWWA/UL/FM rating 250 psig/17 barg; 18" – 24"/DN450 – DN600 AWWA rating 250 psig/17 barg, UL rating 175 psig/12 barg, FM Approved rating 250 psig/17 barg
- Flange End drilling meets: ANSI B16.1, Class 125 and ANSI B16.42, Class 150 Flat Face. Optional PN10, PN16 drilling. Mechanical Joint also available.
- Fitted with End Covers as standard

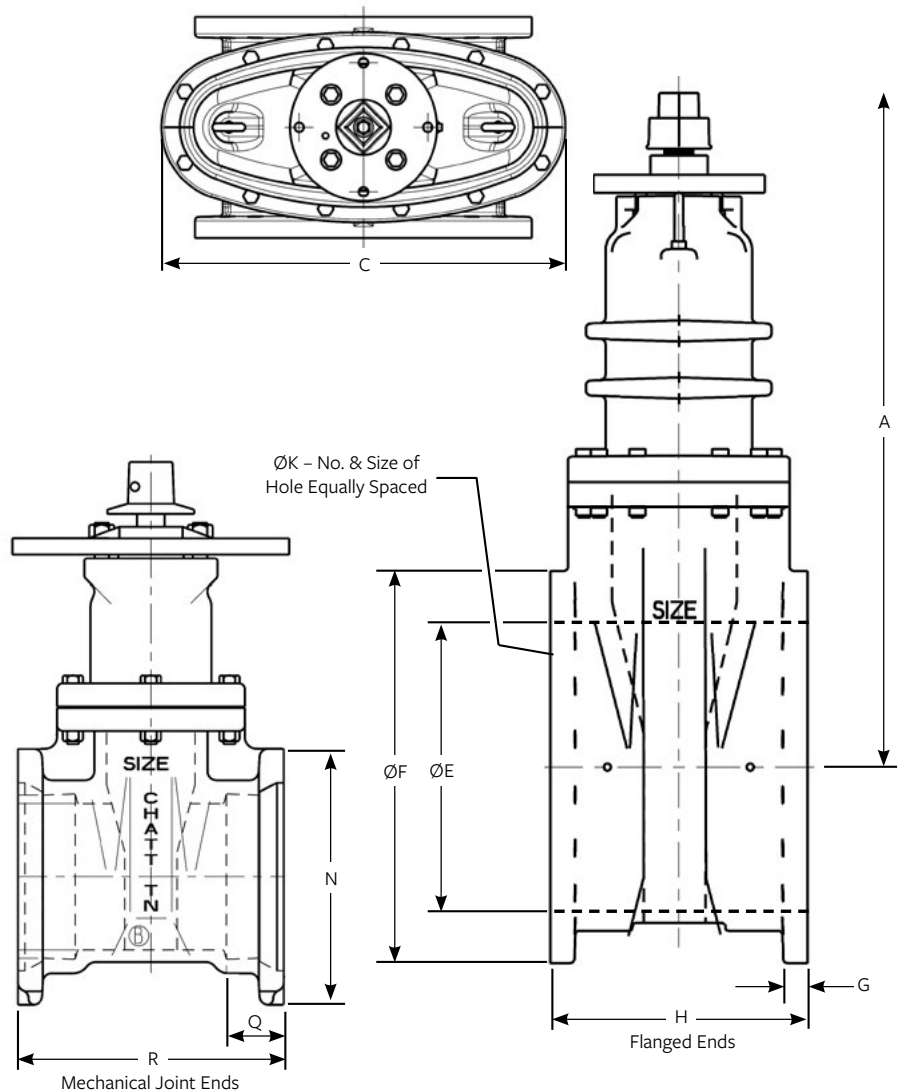

DIMENSION - INCHES (MM)

Valve Size	A	C	ØE	ØF	G	H	NO.-ØK	R	N	Q
14"/DN350	32.75 (832)	24.92 (633)	14.38 (365)	21.00 (533)	1.42 (36)	15.06 (383)	12 - 1.12 (28)	19.88 (505)	20.25 (514)	3.50 (89)
16"/DN400	37.88 (962)	26.58 (675)	16.00 (400)	23.50 (597)	1.05 (27)	16.06 (408)	16 - 1.12 (28)	19.75 (502)	22.56 (573)	3.50 (89)
18"/DN450	44.19 (1122)	30.50 (775)	18.38 (467)	25.00 (635)	1.05 (27)	17.00 (432)	16 - 1.25 (32)	21.00 (533)	24.87 (632)	3.50 (89)
20"/DN500	48.25 (1225)	33.75 (857)	20.38 (518)	27.50 (698)	1.78 (45)	18.00 (450)	20 - 1.25 (32)	21.50 (546)	27.24 (692)	3.50 (89)
24"/DN600	53.88 (1369)	39.50 (1003)	24.38 (619)	32.00 (800)	1.25 (32)	20.00 (500)	20 - 1.38 (35)	23.50 (597)	31.88 (810)	3.50 (89)

WEIGHT - LB. (KG)

Valve Size	14"/DN350	16"/DN400	18"/DN450	20"/DN500	24"/DN600
Flanged	659 (299)	841 (381)	1298 (589)	1640 (744)	2488 (1129)
MJ*	650 (295)	931 (422)	1298 (589)	1640 (744)	2423 (1099)

For more information about us or to view our full line of products, please visit www.mueller-international.com or call International Customer Service at:

UK: +44.1438.487410 Dubai: +971.4.214.6640 Singapore: +65.6816.3088 USA: +1.800.423.1323 | international@muellerwp.com

Mueller refers to one or more of Mueller Water Products, Inc. a Delaware corporation ("MWP"), and its subsidiaries. MWP and each of its subsidiaries are legally separate and independent entities when providing products and services. MWP does not provide products or services to third parties. MWP and each of its subsidiaries are liable only for their own acts and omissions and not those of each other. MWP brands include Mueller®, Echologics®, Hydro Gate®, Hydro-Guard®, Jones®, Krausz®, Mi.Net®, Milliken®, Pratt®, Pratt Industrial®, Singer®, and U.S. Pipe Valve & Hydrant. Please see muellerwp.com/brands to learn more.

© 2020 Mueller Water Products, Inc. All Rights Reserved. The trademarks, logos and service marks displayed in this document are the property of Mueller Water Products, Inc., its affiliates or other third parties. Products above marked with a section symbol (§) are subject to patents or patent applications. For details visit www.muellerwp.com.

