

MUELLER

R-2361+ RESILIENT WEDGE GATE VALVE

OS&Y – PLUS: 2" – 12"/DN50 – DN300

PRODUCT FEATURES

- Outside Screw & Yoke (OS&Y), Standard-PLUS (+) Gate Valve.
- Iron Body, Bonnet, and Yoke.
- Mueller Pro-Gard® 2-Pass Fusion Bonded Epoxy Coating covers all cast surfaces inside and out – 10 mils (250 µm) minimum. Meets requirements of AWWA/ANSI C550.
- Meets requirements of AWWA/ANSI C515 and is certified to ANSI/NSF 61 & 372.
- Iron wedge, symmetrical and fully encapsulated with molded rubber; no exposed iron.
- Polymer cap bearings on wedge guides.
- Everdur Bronze Stem.
- 316 Bolts, Nuts and Washers.
- 10-year limited warranty.
- 2"– 12"/DN50 – DN300: 350 psig/24 barg AWWA/UL/FM WP, 700 psig/48 barg TP.
- UL 262 listed, FM 1120/1130 approved.
- Meets AWWA C515 requirements.
- Flange End drilling meets: ANSI B16.1, Class 125 and ANSI B16.42, Class 150 Flat Face. Optional PN10, PN16 drilling.
- Fitted with End Covers as standard.



Image shown
2"–6"/DN50 – DN150 bonnet/yoke combo.
8"–12"/DN200 – DN300 bonnet and yoke
are two pieces.
Contact for option details.

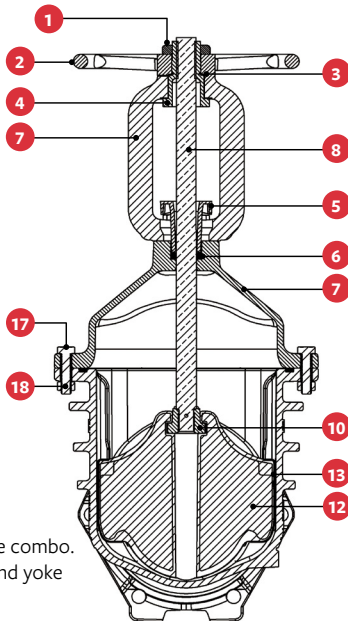

PARTS LIST (TYP.)

ID	PART NAME	MATERIAL
1	Cap Nut	Bronze ASTM B62/B584
2	Handwheel	Ductile Iron ASTM A536
3	Thrust Washer	Brass
4	Bush Nut	Bronze ASTM B62
5	Gland Flange	Ductile Iron ASTM A536
6	Stem Packing*	Lube Flax
7	Bonnet/Yoke	Ductile Iron ASTM A536 (See Note 1)
8	Stem	Silicon Bronze ASTM B98 (C66100)
9	O-Ring	Nitrile ASTM D2000
10	Wedge Nut	Bronze ASTM B584
11	Pin. Type E	Silicon Bronze
12	Wedge	(See Note 2)
13	Guide Cap	Acetal
14	Bonnet Gasket	Nitrile ASTM D2000
15	Body	Ductile Iron ASTM A536
16	Gland Bolt	316 Stainless Steel ASTM F593
17	Bonnet Bolt	316 Stainless Steel ASTM F593
18	Bonnet Nut	316 Stainless Steel ASTM F594
19	Gland Nut	Silicon Bronze ASTM B98

Notes:

1. 2" – 6"/DN50 – DN150 Bonnet and Yoke are one piece.
2. Rubber Encapsulated Ductile Iron Wedge Rubber – EPDM ASTM D2000.

*STEM PACKING INFORMATION

Valve Size	2"/DN50, 2½"/DN65, 3"/DN80	4"/DN100
Part No./Quantity	175972/4	176477/4
Size – inches (mm)	¼ (6) x 3⅝ (92)	¼ (6) x 4¼ (108)
Valve Size	6"/DN150	8"/DN200
Part No./Quantity	170712/4	175937/4
Size – inches (mm)	⅝ (8) x 4¾ (121)	⅝ (8) x 5⅝ (130)
Valve Size	10"/DN250	12"/DN300
Part No./Quantity	175975/4	170749/3
Size – inches (mm)	⅝ (8) x 5½ (133)	⅝ (10) x 6⅝ (161)

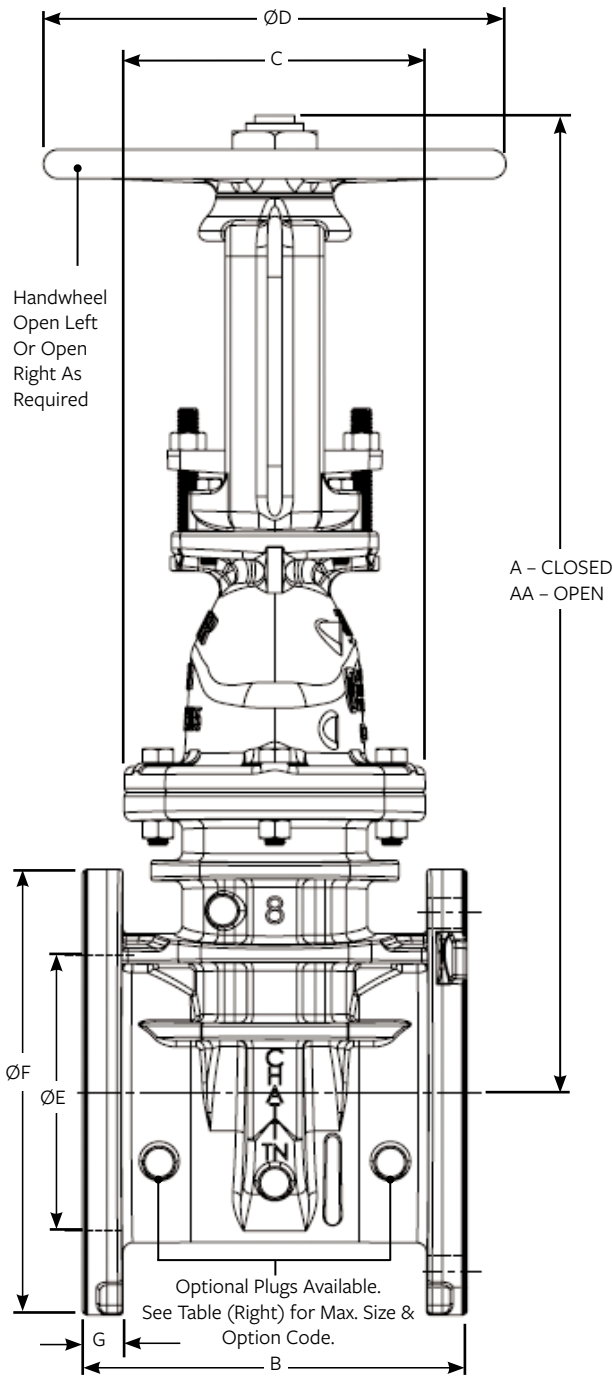

DIMENSIONS – INCHES (MM)

VALVE SIZE	A-CLOSED	AA-OPEN	B	C*
2"/DN50	14.09 (357)	16.69 (424)	7.00 (178)	7.02 (178)
2½"/DN65	15.91 (404)	19.56 (497)	7.50 (191)	8.63 (219)
3"/DN80	15.66 (398)	19.31 (490)	8.00 (203)	8.63 (219)
4"/DN100	19.00 (483)	23.68 (601)	9.00 (229)	10.79 (274)
6"/DN150	24.50 (622)	31.38 (797)	10.50 (267)	13.50 (343)
8"/DN200	29.50 (749)	38.50 (978)	11.50 (292)	16.36 (416)
10"/DN250	35.75 (908)	47.00 (1194)	13.00 (330)	19.99 (508)
12"/DN300	40.50 (1028)	53.50 (1359)	14.00 (356)	21.00 (533)

VALVE SIZE	ØD	ØE THRU Ø	ØF	G
2"/DN50	7.00 (178)	2.30 (58)	6.00 (152)	0.68 (17)
2½"/DN65	7.00 (178)	2.80 (71)	7.00 (178)	0.75 (19)
3"/DN80	7.00 (178)	3.30 (84)	7.50 (191)	0.80 (20)
4"/DN100	10.00 (254)	4.31 (109)	9.00 (229)	1.03 (26)
6"/DN150	12.00 (305)	6.30 (160)	11.00 (279)	1.07 (27)
8"/DN200	14.00 (356)	8.30 (211)	13.50 (343)	1.19 (30)
10"/DN250	16.00 (406)	10.30 (262)	16.00 (406)	1.29 (33)
12"/DN300	16.00 (406)	12.30 (312)	19.00 (483)	1.35 (34)

*C dimension is the overall width of the bonnet flange.

OPTIONAL PLUGS

VALVE SIZE	R2361 MAX. TAP SIZE	OPTION NO.	TAP SIZE
2"/DN50	¾" (19)	0008	½" (13)
2½"/DN65	½" (13)	0054	¾" (19)
3"/DN80	½" (13)	0062	1" (25)
4"/DN100	¾" (19)	0355	1¼" (32)
6"/DN150	1" (25)	0070	1½" (38)
8"/DN200	1¼" (32)	0366	2" (50)
10"/DN250	1¼" (32)		
12"/DN300	2" (50)		

WEIGHT – LB. (KG)

Valve Size	2"/DN50	2½"/DN65	3"/DN80	4"/DN100	6"/DN150	8"/DN200	10"/DN250	12"/DN300
Weight	41 (19)	64 (29)	65 (29)	96 (44)	150 (68)	230 (104)	348 (158)	477 (216)

For more information about us, or to view our full line of products, please visit www.mueller-international.com or call International Customer Service at:

UK: +44.1438.487410 Dubai: +971.4.214.6640 Singapore: +65.6816.3088 USA: +1.800.423.1323 | International@muellerwp.com

Mueller refers to one or more of Mueller Water Products, Inc. a Delaware corporation ("MWP"), and its subsidiaries. MWP and each of its subsidiaries are legally separate and independent entities when providing products and services. MWP does not provide products or services to third parties. MWP and each of its subsidiaries are liable only for their own acts and omissions and not those of each other. MWP brands include Mueller®, Echologics®, Hydro Gate®, Hydro-Guard®, Jones®, Krausz®, Mi.Net®, Milliken®, Pratt®, Pratt Industrial®, Singer®, and U.S. Pipe Valve & Hydrant. Please see muellerwp.com/brands to learn more.

© 2020 Mueller Water Products, Inc. All Rights Reserved. The trademarks, logos and service marks displayed in this document are the property of Mueller Water Products, Inc., its affiliates or other third parties. Products above marked with a section symbol (§) are subject to patents or patent applications. For details visit www.mwppat.com.