

MUELLER

A-2361+ RESILIENT WEDGE GATE VALVE

NRS – PLUS: 14" – 24"/DN350 – DN600

PRODUCT FEATURES

- Non-Rising Stem (NRS), Standard-PLUS (+) Gate Valve.
- 2" square Operating Nut (optional Handwheel).
- 14" – 24"/DN350 – DN600. Larger Valves through 54"/DN1350 also available.
- All Ductile Iron Body and Bonnet.
- Mueller Pro-Gard® 2-Pass Fusion Bonded Epoxy Coating covers all cast surfaces inside and out – 10 mils (250 µm) minimum. Meets requirements of AWWA/ANSI C550.
- Meets requirements of AWWA/ANSI C515 and is certified to ANSI/NSF 61 & 372.
- Silicon Bronze Stem.
- 316 Bolts, Nuts and Washers.
- Antifriction washer above and below thrust collar.
- Ductile Iron Wedge, symmetrical and fully encapsulated with molded EPDM rubber; no exposed iron.
- 10-year limited warranty.
- UL 262 Listed, FM 1120/1130 Approved.
- Pressure rating: AWWA 250 psig/17 barg. UL/FM rating: 14" & 16"/DN350 & DN400 250 psig/17 barg; 18" – 24"/DN450 – DN600 UL rating 175 psig/12 barg, FM rating 250 psig/17 barg.
- Flange End drilling meets: ANSI B16.1 Class 125 Flat Face and ANSI B16.42 Class 150 Flat Face. 14" & 16"/DN350 & DN400 optional PN10, PN16 drilling.
- Fitted with End Covers as standard.

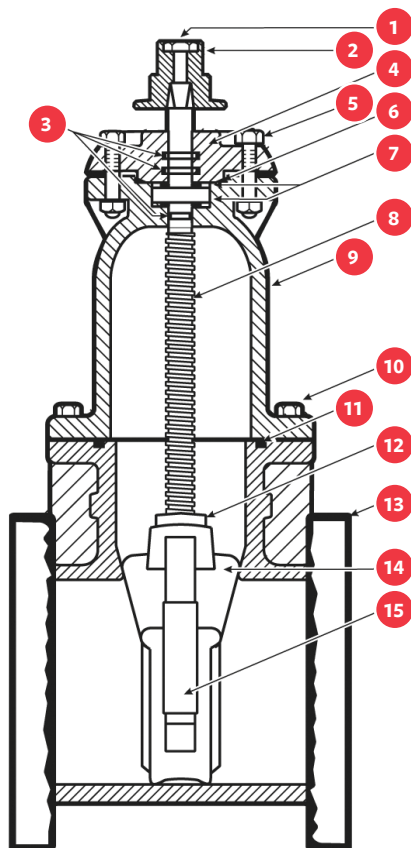

PARTS LIST

ID	PART NAME	MATERIAL
1	Wrench Nut	Cast Iron* ASTM A126 CL.B
2	Wrench Nut Cap Screw	316 Stainless Steel
3	Stem O-Rings	EPDM ASTM D2000
4	Stuffing Box	Ductile Iron ASTM A536**
5	Stuffing Nuts & Bolts	316 Stainless Steel
6	Stuffing Box O-Ring	EPDM ASTM D2000
7	Anti Friction Washers	Acetal
8	Stem	Silicon Bronze (See Note 1)
9	Bonnet	Ductile Iron ASTM A536**
10	Bonnet Nuts & Bolts	316 Stainless Steel
11	Bonnet O-Ring	EPDM ASTM D2000
12	Stem Nut	Bronze ASTM B62
13	Body	Ductile Iron ASTM A536**
14	Wedge	Ductile Iron ASTM A536** (See Note 2)
15	Guide Cap Bearings	Acetal
16	Hand Wheel (Not Shown)	Cast Iron* ASTM A126 CL.B

*Manufacturers option to change to Ductile Iron ASTM A536.

**ASTM A536 Ductile Iron Grade 65-45-12 (minimum strength).

NOTES:

1. 14" & 16"/DN350 & DN400 ASTM B98 (C66100); 18" – 24"/DN450 – DN600 ASTM B763 (C99400).
2. ASTM A536 fully encapsulated in EPDM ASTM D2000 molded rubber with no iron exposed.

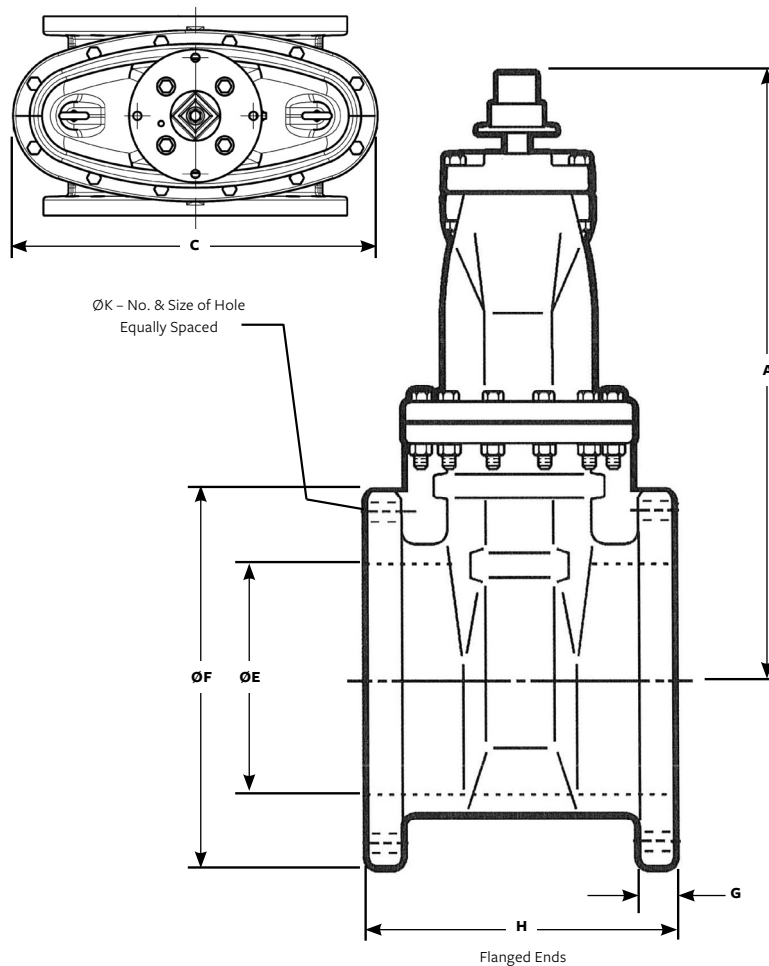

DIMENSIONS – INCHES (MM)

VALVE SIZE	A	C	ØE	ØF	G	H	NO. - ØK
14"/DN350	32.75 (832)	24.92 (633)	14.38 (365)	21.00 (533)	1.42 (36)	15.06 (383)	12 - 1.12 (28)
16"/DN400	37.88 (962)	26.58 (675)	16.00 (400)	23.50 (597)	1.05 (27)	16.06 (408)	16 - 1.12 (28)
18"/DN450	44.19 (1122)	30.50 (775)	18.38 (467)	25.00 (635)	1.05 (27)	17.00 (432)	16 - 1.25 (32)
20"/DN500	48.25 (1225)	33.75 (857)	20.38 (518)	27.50 (698)	1.78 (45)	18.00 (450)	20 - 1.25 (32)
24"/DN600	53.88 (1369)	39.50 (1003)	24.38 (619)	32.00 (800)	1.25 (32)	20.00 (500)	20 - 1.38 (35)

WEIGHT – LB (KG)

Valve Size	14"/DN350	16"/DN400	18"/DN450	20"/DN500	24"/DN600
Flanged	659 (299)	841 (381)	1298 (589)	1640 (744)	2488 (1129)
MJ*	50 (295)	931 (422)	1298 (589)	1640 (744)	2423 (1099)

*Weights approximate, MJ less accessories

For more information about us, or to view our full line of products, please visit www.mueller-international.com or call International Customer Service at:

UK: +44.1438.487410 Dubai: +971.4.214.6640 Singapore: +65.6816.3088 USA: +1.800.423.1323 | International@muellerwp.com

Mueller refers to one or more of Mueller Water Products, Inc. a Delaware corporation ("MWP"), and its subsidiaries. MWP and each of its subsidiaries are legally separate and independent entities when providing products and services. MWP does not provide products or services to third parties. MWP and each of its subsidiaries are liable only for their own acts and omissions and not those of each other. MWP brands include Mueller®, Echologics®, Hydro Gate®, Hydro-Guard®, Jones®, Krausz®, Mi.Net®, Milliken®, Pratt®, Pratt Industrial®, Singer®, and U.S. Pipe Valve & Hydrant. Please see muellerwp.com/brands to learn more.

© 2020 Mueller Water Products, Inc. All Rights Reserved. The trademarks, logos and service marks displayed in this document are the property of Mueller Water Products, Inc., its affiliates or other third parties. Products above marked with a section symbol (§) are subject to patents or patent applications. For details visit www.mwppat.com.

F 13769 4/20

MUELLER