

# Mueller Canada

## STAINLESS STEEL TAPPING SLEEVE 4 IN. - 24 IN. (100 MM - 600 MM)

Corrosion resistance / High pressure sealing

### 304 Stainless Steel, Carbon Steel or Ductile Iron Flanges

ANSI B16.1, Class 125 drilling with a machined centering recess for tapping valves in accordance with MSS-SP 60. Fully machined flange face for precise alignment of gate valve and drilling machine. Carbon steel and ductile iron flanges are factory-coated with a water based enamel for corrosion protection.

### Test Plug

3/4" NPT brass plug for pressure testing is standard. Optional stainless steel plug available. Plug has a square head for easy removal and installation.

### Side Bars

Heavy gauge 304L stainless steel construction for maximum bending resistance. All side bars are drop-in bolt design for ease of installation.

### Nuts

Heavy hex 304 stainless steel.

### Bolts

Bolts are 304 stainless steel, coated with an anti-galling compound. Rolled threads facilitate spin assembly of nuts.

### Washers

304 stainless steel washers prevent galling and facilitate tightening.

### NSF 61 Certified

### Welding

Welds are continuous bead (MIG), utilizing state-of-the-art robotic welding equipment. Robotic welding provides a consistently superior weld versus the manual method.

### Shell

The shell is plasma cut to exacting tolerances. 304L stainless steel is low carbon to minimize carbide precipitation corrosion. The entire sleeve is fully passivated (not just the weld sections) to maintain optimum corrosion resistance.

### Gasket

Provides full 360° seal. Made of virgin NBR (R78) material, the "Waffle" design provides an optimal watertight seal. An integral "raised" ring seal at the outlet (at base of pipe) aids in high pressure sealing.

### Integral Gap Bridging

Unique design eliminates the need for separate gap bridges and makes installation easier. This design reduces deformation of the bridge at high torques and aids in the assembly of the sleeve.

### High Pressure Sealing

4"-12" 250 psig; 14"-24" 200 psig

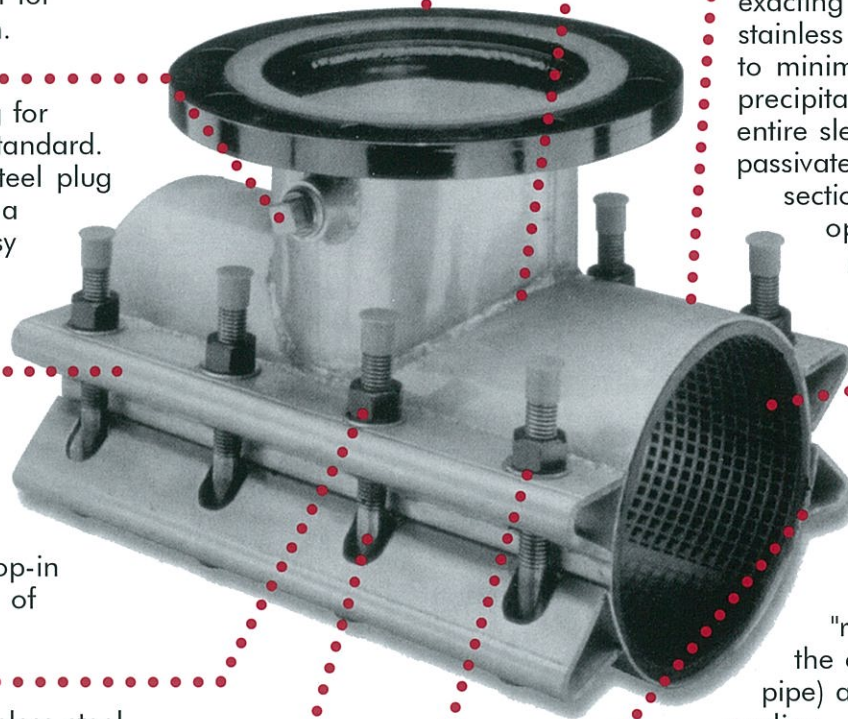

For dimensions and ordering information refer to Mueller Co. catalogue pages 12.6 & 12.7

[www.muellercanada.com](http://www.muellercanada.com)

Barrie, Ontario - Saint-Jérôme, Québec

All products must be installed and maintained in accordance with applicable instructions and/or standards.