

No.	DESCRIPTION	MATERIAL
1	METER FLANGE	CST LOW LEAD BRASS ALLOY
2	PJ GASKET	ASTM D2000 (BUNA N)
3	PJ WASHER	POLYPROPYLENE
4	PJ CPLG NUT	CAST BRASS ASTM B62 ALLOY C83600

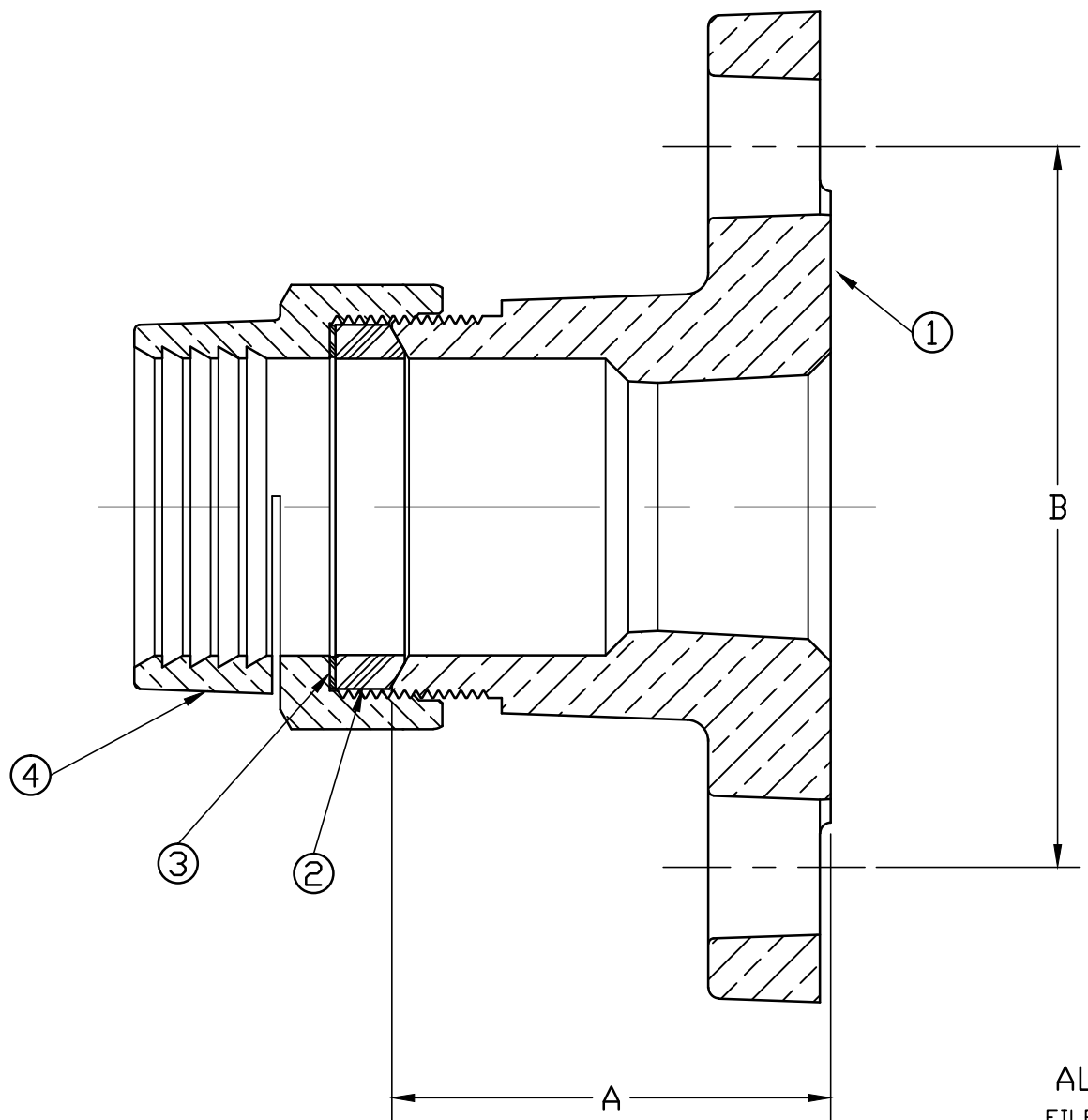

SIZE	A	B
1-1/2	2.44	4.00
2	2.56	4.50

ALL WETTED PARTS ARE LOW LEAD BRASS ALLOY

FILEPATH: PROD-ENG\MUELLER\ASYSUBMITTALS\P10127N

DWG NUMBER
P10127N
442-MRKTG

TITLE TO AND OWNERSHIP OF THIS ENGINEERING DATA REMAINS IN Mueller Co. NO USE IS TO BE MADE OF THIS DATA EXCEPT AS SPECIFICALLY AUTHORIZED BY Mueller Co. ASSENT ON THE PART OF THE RECIPIENT TO THESE CONDITIONS IS PRESUMED.

DRFTR	JGarvin	9/23/10	Mueller Co.	UNLESS OTHERWISE NOTED THIRD ANGLE PROJECTION SURFACE PREPARATION: BREAK CORNER(S) ---- .000 SURFACE FINISH -- XX RMS TOLERANCE(S): LINEAR ----- ± .000 ANGULAR ----- ± 0°00'	REF. No.	SCALE FULL	
CHKR							
ENGR							
MGR							
	BY	DATE	STK No:	MAT'L:			
REV	ECR	DESCRIPTION	DATE	BY	CHKR	DESCR.	DWG NUMBER
						LLB METER FLANGE SERVICE FITTING (MTR FLG x PJ CTS)	P10127N
PER EST NO: DXXXX EST FIN WT = 0.0000 lbs							