

No.	DESCRIPTION	MATERIAL
1	SPUD	CAST NO LEAD BRASS ALLOY
2	COPPER GASKET	COPPER ASTM B152 ALLOY C11000
3	PJ GASKET	ASTM D2000 (BUNA N)
4	PJ WASHER	POLYPROPYLENE
5	PJ CPLG NUT	CAST BRASS ASTM B62 ALLOY C83600

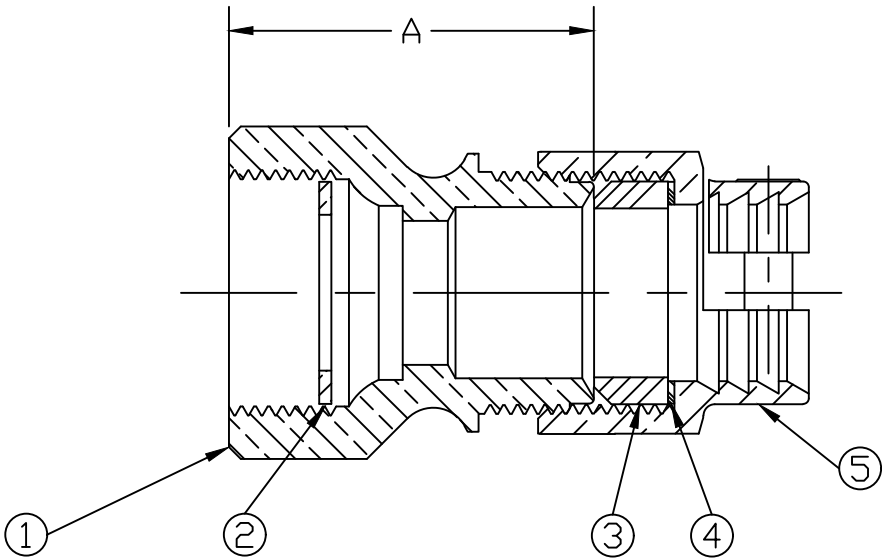

SIZE	A
3/4	1.90
3/4x1	2.32
1	2.52
1x3/4	2.06
1-1/4x1	2.84
1-1/2	2.81
2	3.19

ALL WETTED PARTS ARE NO LEAD BRASS ALLOY

FILEPATH: PROD-ENG\MUELLER\ASYSUBMITTALS\P15071N

						DRFTR	RWB	4/15/15	MUELLER	THIRD ANGLE PROJECTION
						CHKR				
						ENGR				
						MGR				
									UNLESS OTHERWISE NOTED	REF. No.
									SURFACE PREPARATION: BREAK CORNER(S) ---- .000 SURFACE FINISH -- XX RMS	
							BY	DATE	TOLERANCE(S): LINEAR ----- ± .000 ANGULAR ----- ± 0°00'	
								STK No:		
								MAT'L:		
								DESCR.	NLB CORPORATION STOP COUPLING (“CS” COUPLING x PJ CTS)	DWG NUMBER P15071N
REV	ECR	DESCRIPTION	DATE	BY	CHKR	PER EST NO: DXXXX EST FIN WT = 0.0000 lbs				

DWG NUMBER
P15071N
442-MRKTG

TITLE TO AND OWNERSHIP OF THIS ENGINEERING DATA REMAINS IN Mueller Co. NO USE IS TO BE MADE OF THIS DATA EXCEPT AS SPECIFICALLY AUTHORIZED BY Mueller Co. ASSENT ON THE PART OF THE RECIPIENT TO THESE CONDITIONS IS PRESUMED