

DWG NUMBER
P1536313N

44-MRKTNG

PJ SIZE	NPT SIZE	BETWEEN CENTERS
1"	3/4"	6-1/2"
1"	3/4"	7-1/2"

No.	DESCRIPTION	MATERIAL
1	BRANCH	CAST LOW LEAD BRASS ALLOY
2	PJ GASKET	ASTM D2000 (BUNA N)
3	PJ WASHER	POLYPROPYLENE
4	PJ CPLG NUT	CAST BRASS ASTM B62 ALLOY C83600

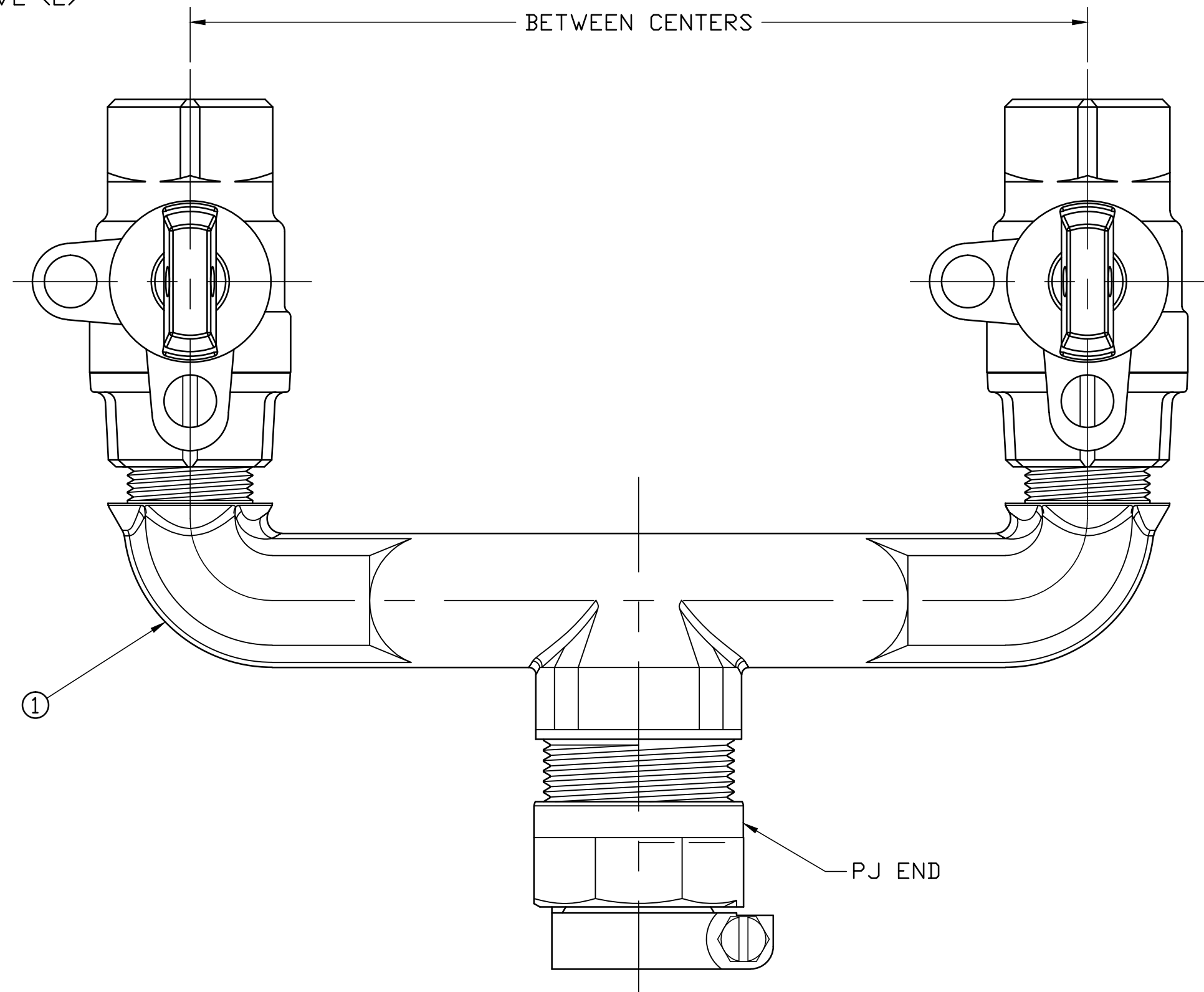
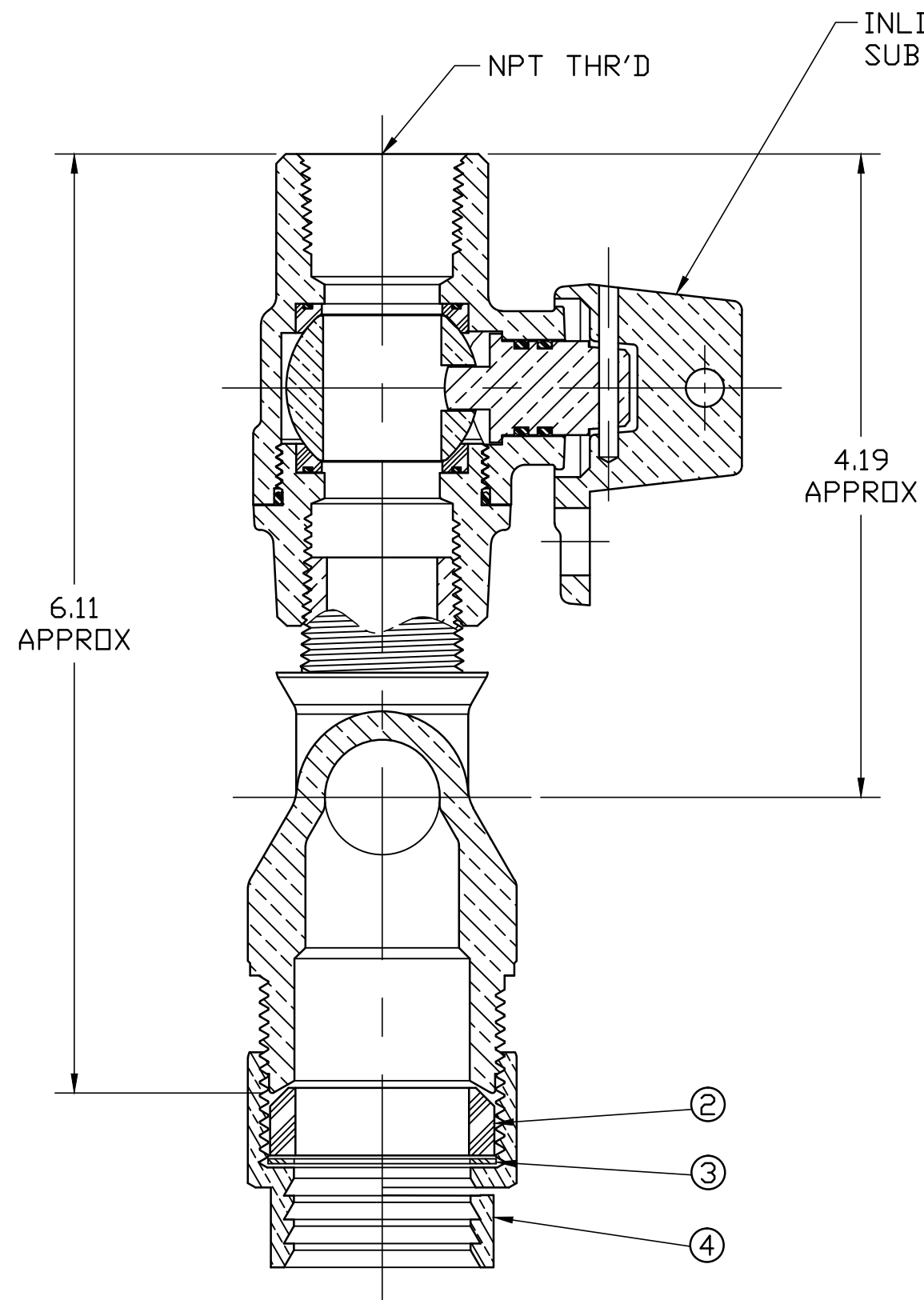

ALL WETTED PARTS ARE LOW LEAD BRASS ALLOY

FILEPATH: PRDD-ENG\MUELLER\APPROVED\P1536313N

DRFTR	RWB	7/10/17	Mueller Co.	UNLESS OTHERWISE NOTED SURFACE PREPARATION: BREAK CORNER(S) ---- .000 SURFACE FINISH -- .000 RMS TOLERANCE(S): LINEAR ----- ± .000 ANGULAR ----- ± 0°00'	THIRD ANGLE PROJECTION	
CHKR					REF. No.	SCALE
ENGR						NONE
MGR						
BY			DATE			
STK No:						
MAT'L:						
DESCR.			LLB U-BRANCH CONNX. PJ CTS x MIP x MIP		DWG NUMBER P1536313N	
REV	ECR	DESCRIPTION	DATE	BY	CHKR	PER EST NO: XXXX EST FIN WT = 0.0000 lbs

TITLE TO AND OWNERSHIP OF THIS ENGINEERING DATA REMAINS IN MUELLER CO. NO USE IS TO BE MADE OF THIS DATA EXCEPT AS SPECIFICALLY AUTHORIZED BY MUELLER CO. ASSENT ON THE PART OF THE RECIPIENT TO THESE CONDITIONS IS PRESUMED.