

DWG NUMBER
P15363N

No.	DESCRIPTION	MATERIAL
1	BRANCH	LEAD FREE BRASS ALLOY ASTM B584
2	PJ GASKET	ASTM D2000 (BUNA N)
3	PJ WASHER	POLYPROPYLENE
4	PJ CPLG NUT	CAST BRASS ALLOY ASTM B584

PJ SIZE	NPT SIZE	BRANCH BETWEEN CENTERS
3/4"	3/4"	7-1/2"
1"	3/4"	6-1/2"
1"	3/4"	7-1/2"
1"	3/4"	13-1/2"
1-1/2"	3/4"	7-1/2"
1"	1"	7-1/2"
1-1/2"	1"	7-1/2"

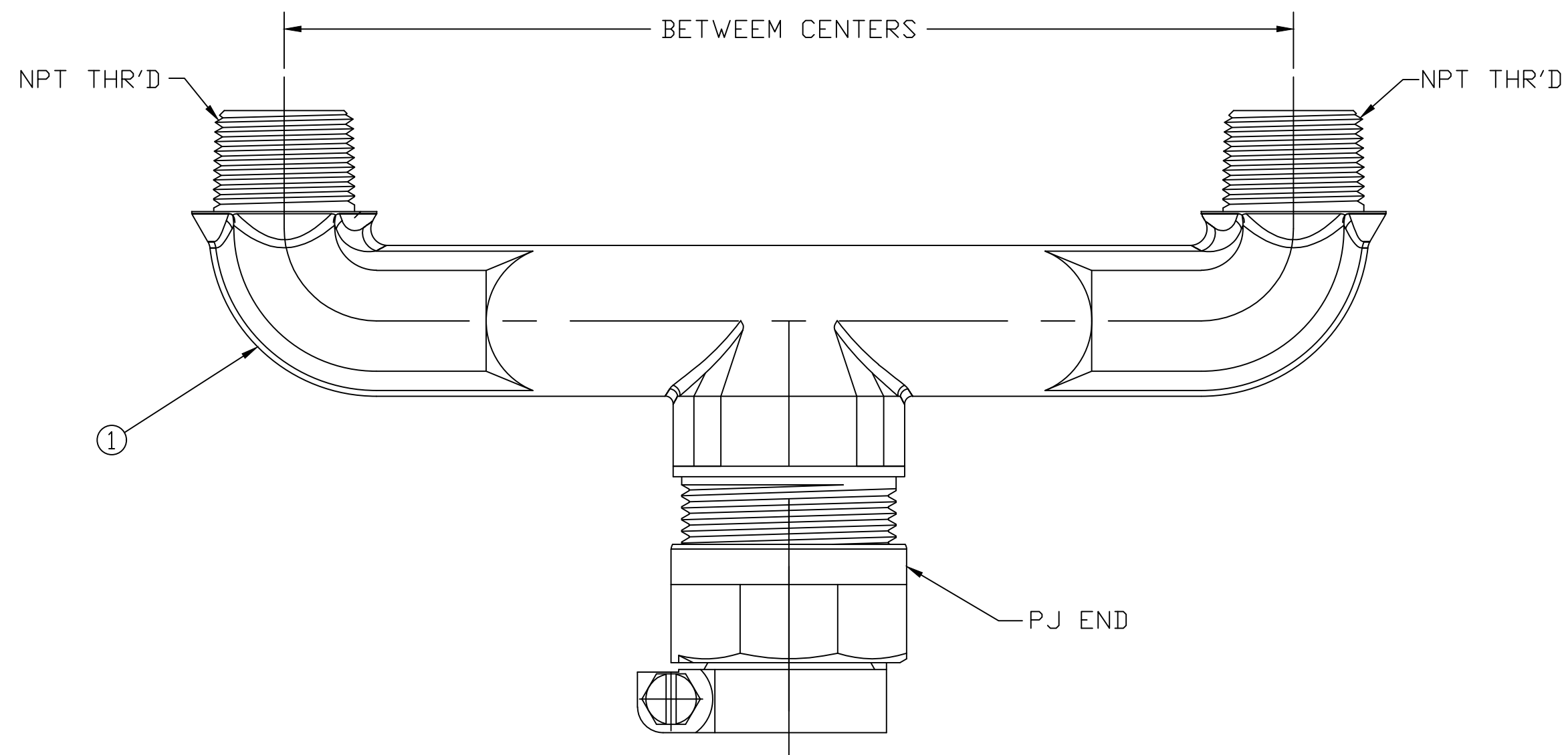
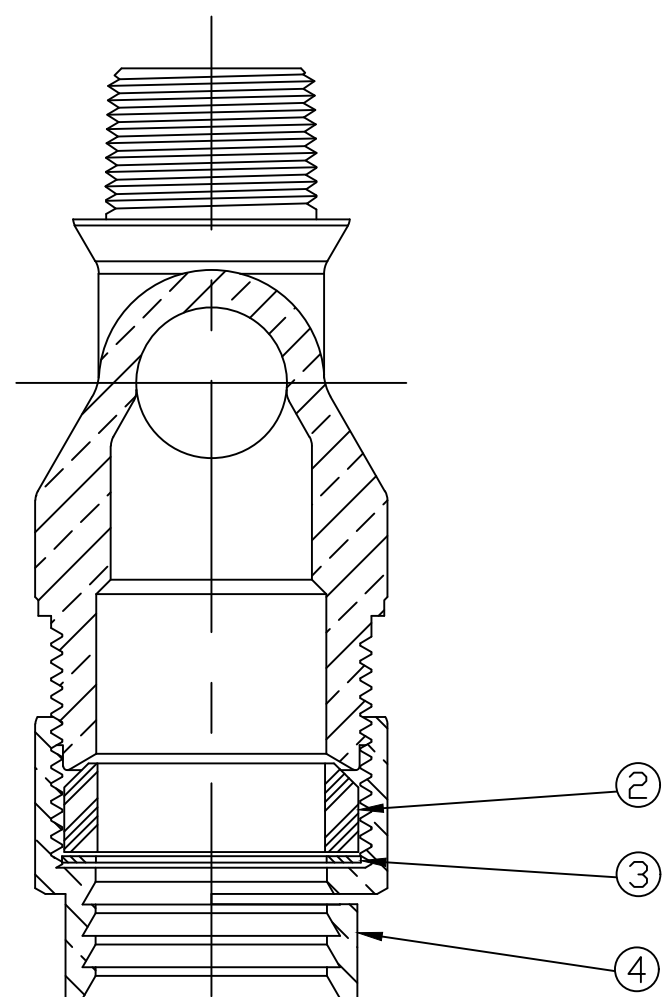

MEETS ALL REQUIREMENTS OF AWWA C800
 ALL WETTED PARTS ARE LEAD FREE BRASS ALLOY C89833/C87850
 ALL NON WETTED PARTS ARE BRASS ALLOY C83600/C87850

DRFTR	AD	03/06/23	MUELLER	THIRD ANGLE PROJECTION 	
CHKR					
ENGR					
MGR					
BY	DATE		UNLESS OTHERWISE NOTED	REF. No.	SCALE
STK No:			SURFACE PREPARATION:		NONE
MAT'L:			BREAK CORNER(S) ---- .000		
			SURFACE FINISH -- XX RMS		
			TOLERANCE(S):		
			LINEAR ----- ± .000		
			ANGULAR ----- ± 0°00'		

TITLE TO AND OWNERSHIP OF THIS ENGINEERING
 DATA REMAINS IN Mueller Co. NO USE IS TO BE
 MADE OF THIS DATA EXCEPT AS SPECIFICALLY
 AUTHORIZED BY Mueller Co. ASSENT ON THE PART
 OF THE RECIPIENT TO THESE CONDITIONS IS PRESUMED

DESCR.	U-BRANCH CONNX. PJ CTS x MIP x MIP	DWG NUMBER P15363N
--------	---------------------------------------	-----------------------