

No.	QTY.	DESCRIPTION	MATERIAL
1	1	SPUD	CAST NO LEAD BRASS ALLOY
2	2	PJ CPLG NUT	CAST BRASS ASTM B62 ALLOY C83600
3	2	PJ GASKET	EPDM D2000
4	2	PJ WASHER	POLYPROPYLENE

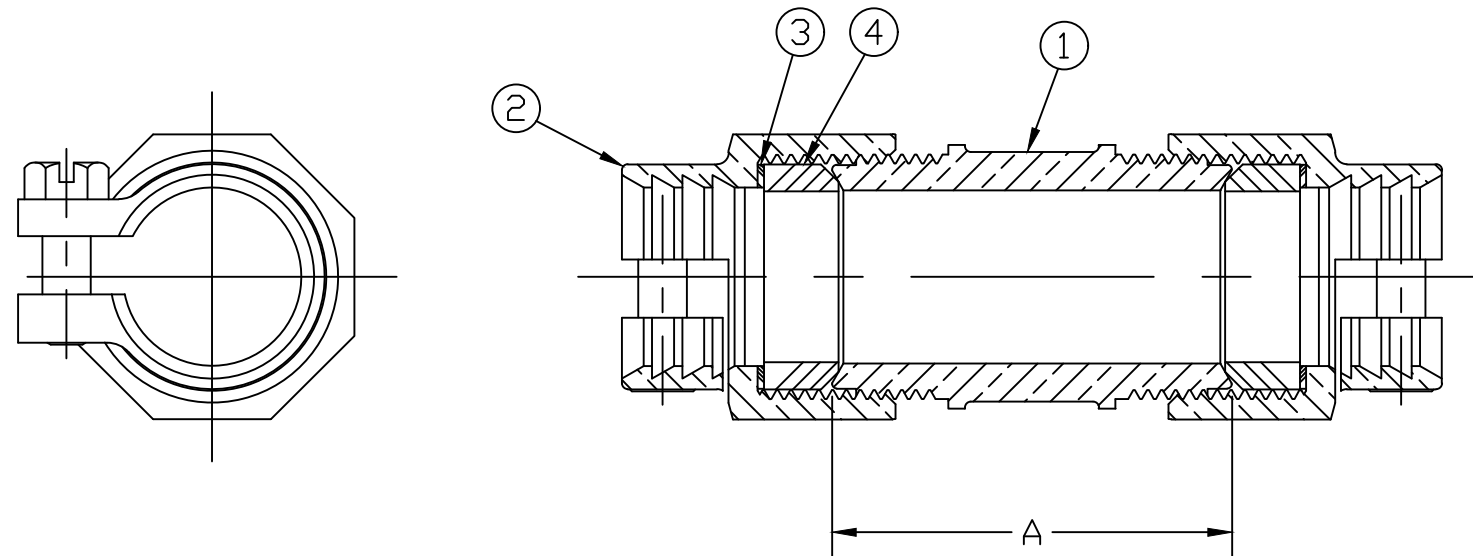

SIZE	A
3/4	2.062
1	2.406
1x3/4	1.835
1-1/2	3.312
1-1/2x1	2.840
2	3.375

ALL WETTED PARTS ARE NO LEAD BRASS ALLOY

FILEPATH: PRODD-ENG\MUELLER\APPROVED\P15403N

						DRFTR	RWB	7/19/13	<b>MUELLER</b>	UNLESS OTHERWISE NOTED THIRD ANGLE PROJECTION SURFACE PREPARATION: BREAK CORNER(S) ---- .000 SURFACE FINISH -- 000 RMS TOLERANCE(S): LINEAR ----- ± .000 ANGULAR ----- ± 0°00'	REF. No.	SCALE NONE
						CHKR						
						ENGR						
						MGR						
							BY	DATE				
								STK No:				
								MAT'L:				
								DESCR.	P-15403 STRAIGHT NLB SERVICE FITTING (PJ CTS x PJ CTS)			DWG NUMBER P15403N
									PER EST NO: DXXXX EST FIN WT = 0.0000 lbs			

TITLE TO AND OWNERSHIP OF THIS ENGINEERING DATA REMAINS IN Mueller Co. NO USE IS TO BE MADE OF THIS DATA EXCEPT AS SPECIFICALLY AUTHORIZED BY Mueller Co. ASSENT ON THE PART OF THE RECIPIENT TO THESE CONDITIONS IS PRESUMED

DWG NUMBER  
P15403N  
442-MRKTG