

No.	DESCRIPTION	MATERIAL
1	PJ CPLG NUT W/ SCREW	CAST BRASS ASTM B62 ALLOY C83600
2	PJ GASKET	BUNA N ASTM D2000
3	PJ PLASTIC WASHER	POLYPROPYLENE
4	SPUD	CAST LOW LEAD BRASS ALLOY
5	COUPLING NUT	CAST BRASS ASTM B62 ALLOY C83600
6	PLAIN GASKET	NEOPRENE RUBBER ASTM D2000
7	RETAINER CUP	STEEL ASTM A245

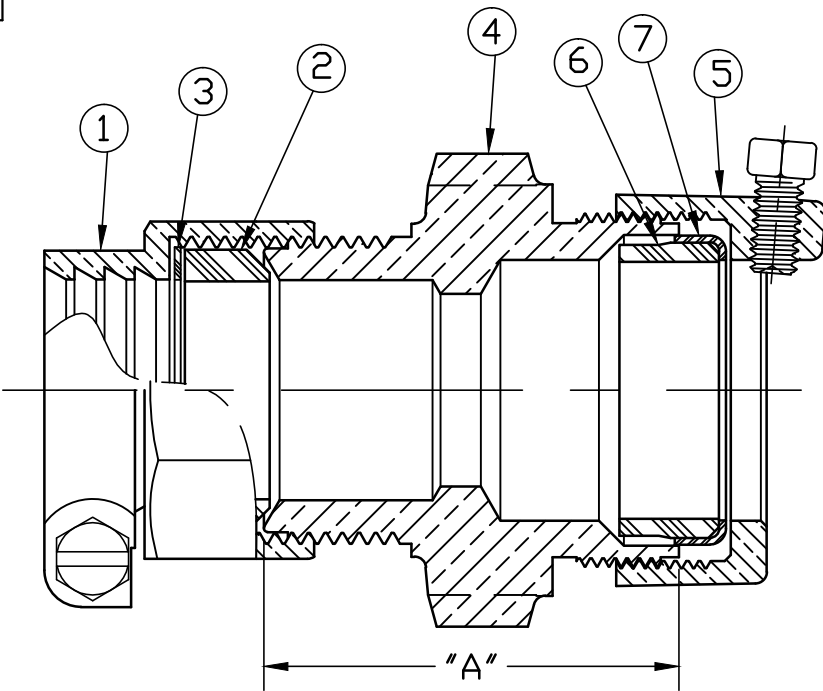

SIZE	A
3/4	1.84
1	2.15

ALL WETTED PARTS ARE LOW LEAD BRASS ALLOY

FILEPATH: PROD-ENG\MUELLER\ASYSUBMITTALS\P15421N

						DRFTR	RWB	4/12/12	Mueller Co.		
						CHKR					
						ENGR					
						MGR					
							BY	DATE	UNLESS OTHERWISE NOTED	THIRD ANGLE PROJECTION	
									SURFACE PREPARATION:		
									BREAK CORNER(S) ---- .000		REF. No.
									SURFACE FINISH -- XX RMS		FULL
									TOLERANCE(S):		
									LINEAR ----- ± .000		
									ANGULAR ----- ± 0°00'		
									STK No:		
									MAT'L:		
									DESCR.		
									PJ CTS x DRESSER STYLE 65 LLB SERVICE FITTING	DWG NUMBER	P15421N
									PER IL NO: 120078	EST FIN WT = 0.000 lbs	

DWG NUMBER
P15421N
442-MRKTNG

TITLE TO AND OWNERSHIP OF THIS ENGINEERING DATA REMAINS IN Mueller Co. NO USE IS TO BE MADE OF THIS DATA EXCEPT AS SPECIFICALLY AUTHORIZED BY Mueller Co. ASSENT ON THE PART OF THE RECIPIENT TO THESE CONDITIONS IS PRESUMED