

No.	DESCRIPTION	MATERIAL
1	SPUD	CAST NO LEAD BRASS ALLOY
2	PJ CPLG NUT	CAST BRASS ASTM B62 ALLOY C83600
3	PJ GASKET	EPDM D2000
4	PJ WASHER	POLYPROPYLENE

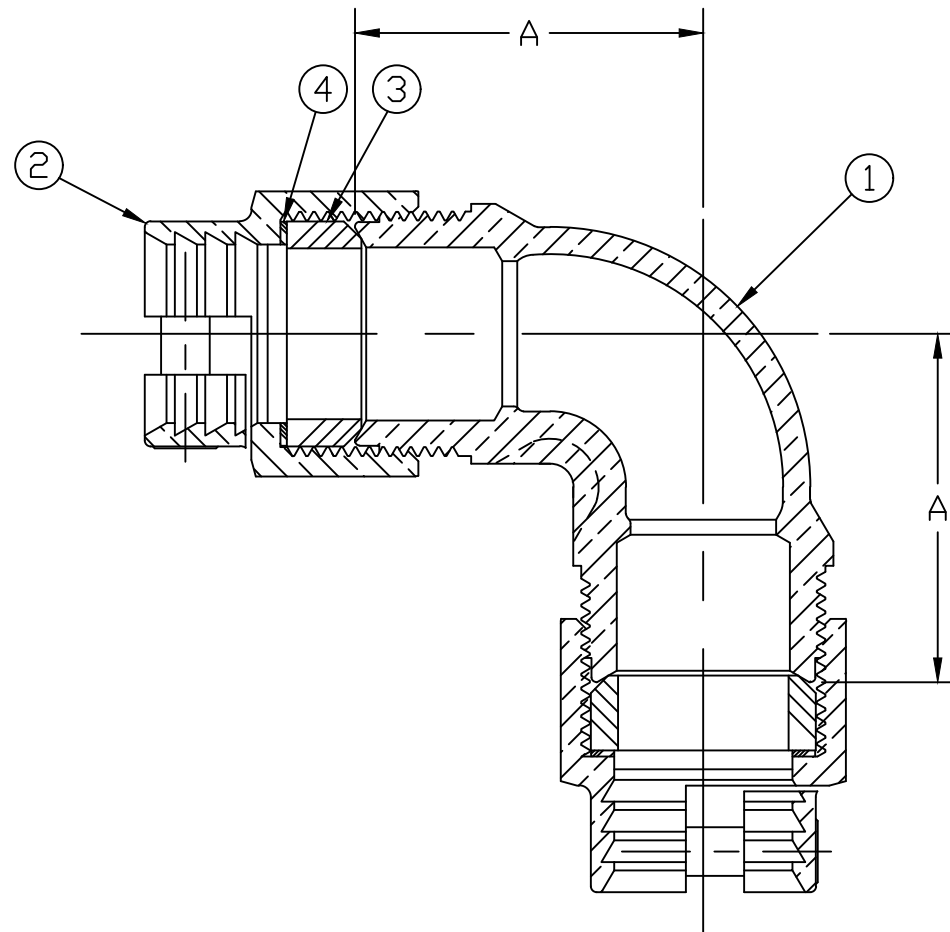

SIZE	A	WRENCH FLATS
3/4	1.79	1.09@BODY
1	2.00	1.31@BODY
1x3/4	2.00	1.34@BODY
1-1/2	2.75	2.22@ENDS
2	3.09	2.72@ENDS

ALL WETTED PARTS ARE NO LEAD BRASS ALLOY

FILEPATH: PROD-ENG\MUELLER\APPROVED\P15526N

						DRFTR	JGarvir	7/16/10	<b>MUELLER</b>	UNLESS OTHERWISE NOTED THIRD ANGLE PROJECTION SURFACE PREPARATION: BREAK CORNER(S) ---- .000 SURFACE FINISH -- XX RMS TOLERANCE(S): LINEAR ----- ± .000 ANGULAR ----- ± 0°00'	REF. No.	SCALE NONE	
						CHKR							
						ENGR							
						MGR							
							BY	DATE					
							STK No:						
							MAT'L:						
							DESCR.	1/4 BEND NLB SERVICE FITTING (PJ CTS ENDS)					
												DWG NUMBER P15526N	

TITLE TO AND OWNERSHIP OF THIS ENGINEERING DATA REMAINS IN Mueller Co. NO USE IS TO BE MADE OF THIS DATA EXCEPT AS SPECIFICALLY AUTHORIZED BY Mueller Co. ASSENT ON THE PART OF THE RECIPIENT TO THESE CONDITIONS IS PRESUMED

PER EST NO: DXXXX EST FIN WT = 0.0000 lbs

DWG NUMBER  
P15526N  
442-MRKTG