

No.	DESCRIPTION	MATERIAL
1	SPUD	LEAD FREE BRASS ALLOY ASTM B584
2	PJ CPLG NUT	CAST BRASS ALLOY ASTM B584
3	PJ GASKET	EPDM D2000
4	PJ WASHER	POLYPROPYLENE

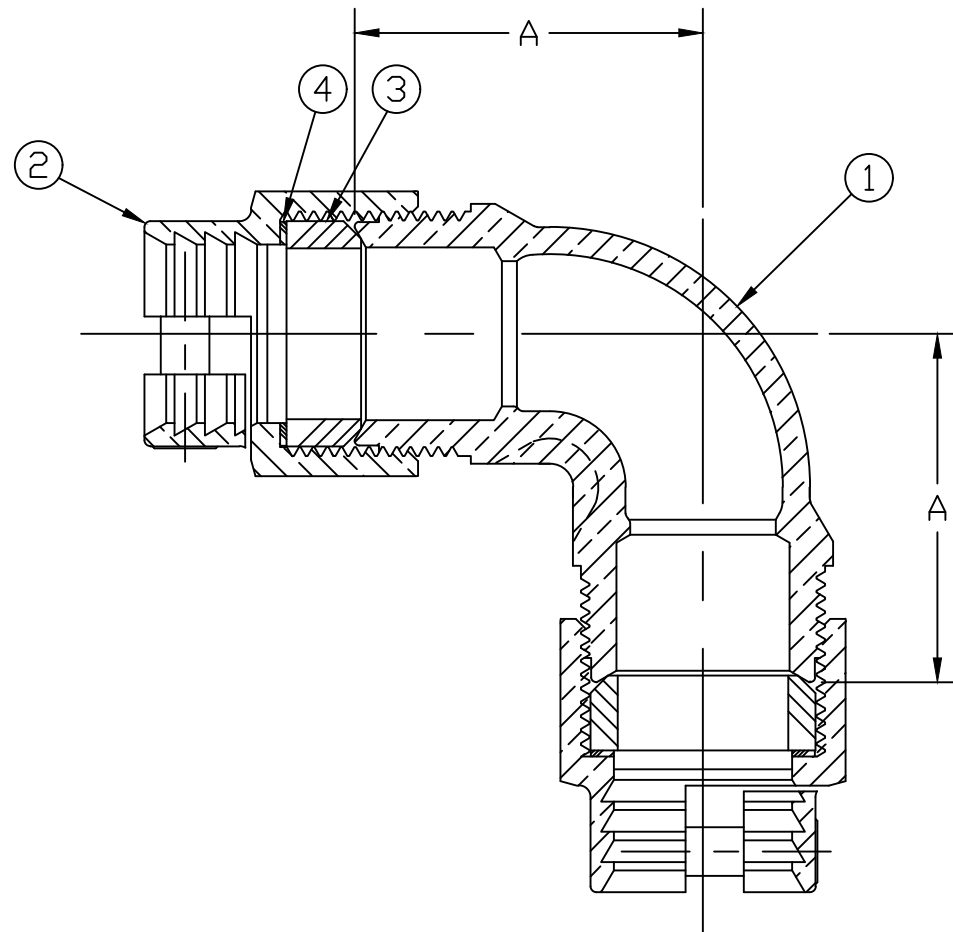

SIZE	A	WRENCH FLATS
3/4	1.79	1.09@BODY
1	2.00	1.31@BODY
1x3/4	2.00	1.34@BODY
1-1/2	2.75	2.22@ENDS
2	3.09	2.72@ENDS

MEETS ALL REQUIREMENTS OF AWWA C800
 ALL WETTED PARTS ARE LEAD FREE BRASS ALLOY C89833/C87850
 ALL NON WETTED PARTS ARE BRASS ALLOY C83600/C87850

DWG NUMBER
P15526N

TITLE TO AND OWNERSHIP OF THIS ENGINEERING
 DATA REMAINS IN Mueller Co. NO USE IS TO BE
 MADE OF THIS DATA EXCEPT AS SPECIFICALLY
 AUTHORIZED BY Mueller Co. ASSENT ON THE PART
 OF THE RECIPIENT TO THESE CONDITIONS IS PRESUMED

DRFTR	AD	03/02/23	MUELLER	
CHKR				
ENGR			UNLESS OTHERWISE NOTED	THIRD ANGLE PROJECTION
MGR				SURFACE PREPARATION: BREAK CORNER(S) ---- .000 SURFACE FINISH -- XX RMS TOLERANCE(S): LINEAR ----- ± .000 ANGULAR ----- ± 0°00'
	BY	DATE	REF. No.	SCALE
STK No:				NONE
MAT'L:	DESCR.			DWG NUMBER
	1/4 BEND SERVICE FITTING (PJ CTS ENDS)			P15526N