

No.	QTY.	DESCRIPTION	MATERIAL
1	1	STEM	NO LEAD BRASS ALLOY
2	2	O-RING	EPDM D2000
3	1	BALL	NO LEAD BRASS ALLOY
4	1	GASKET - SEAL	EPDM D2000
5	1	BODY	CAST NO LEAD BRASS ALLOY
6	1	CAP	CAST BRASS ASTM B62 ALLOY C83600
7	1	SEALING PLUG	CAST NO LEAD BRASS ALLOY
8	1	ROLLPIN	STAINLESS STEEL ASTM A240 TYPE 302
9	1	O-RING	EPDM D2000
10	1	PJ GASKET	EPDM D2000
11	1	PJ WASHER	POLYPROPYLENE
12	1	CLPG NUT SUB	CAST BRASS ASTM B62 ALLOY C83600

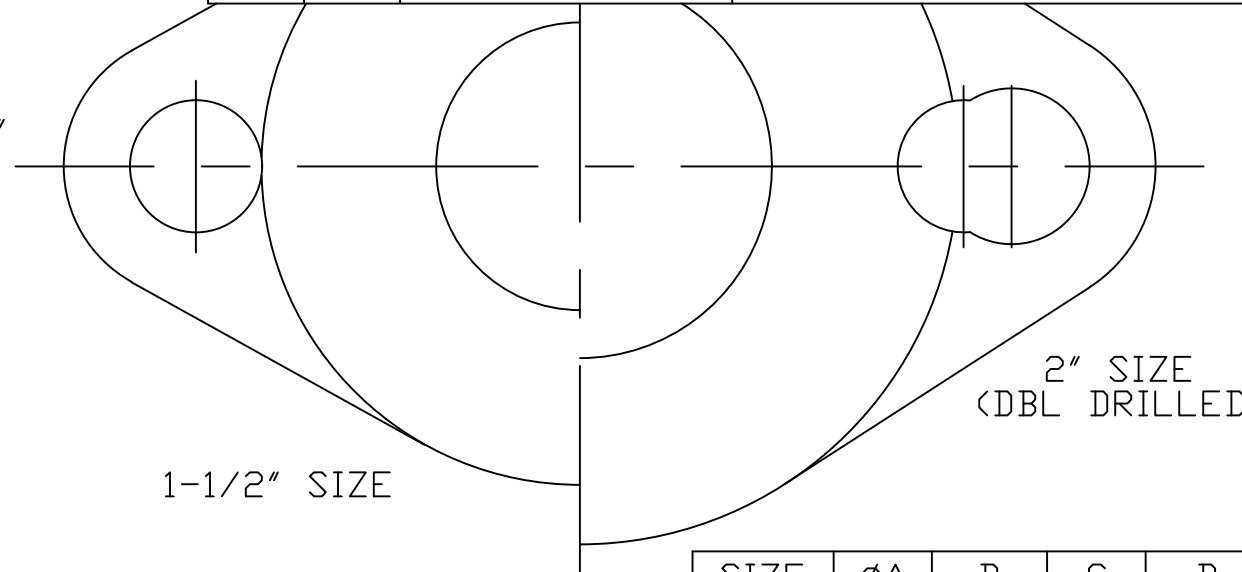

SIZE	ØA	B	C	D	E
1-1/2	1.50	1.81	3.00	3.53	6.53
2	2.00	2.19	3.78	4.22	8.00

ALL WETTED PARTS ARE NO LEAD BRASS ALLOY

FILEPATH: PROD-ENG\MUELLER\ASYSUBMITTALS\P24276N

DRFTR	JGarvin	2/12/08
CHKR		
ENGR		
MGR		
BY		DATE



UNLESS OTHERWISE NOTED
 SURFACE PREPARATION:
 BREAK CORNER(S) ---- .000
 SURFACE FINISH -- XX RMS
 TOLERANCE(S):
 LINEAR ----- ± .000
 ANGULAR ----- ± 0°00'

THIRD ANGLE PROJECTION

REF. No. SCALE
 NONE

STK No:	
MAT'L:	
DESCR.	NLB ANGLE METER BALL VALVE (PJ CTS x METER)
DWG NUMBER	P24276N

REV	ECR	DESCRIPTION	DATE	BY	CHKR
PER EST NO:	DXXXX	EST FIN	WT = 0.0000	lbs	

DWG NUMBER
 P24276N
 442-MRKTG