

METER SIZE	1-1/2"	2"
A (MINIMUM)	12"	12"
B	13-1/4"	17-1/4"
FIP X SOLDER X FIP TEE	509704	530146
TIE BAR SUB ASSEMBLY	282970E	681558
FULL PORT BALL VALVE	500B242860IN	550B242860IN
METER COUPLING	500HI4204N	550HI4204N

ITEM NO	PART NUMBER	QTY	DESCRIPTION	MATERIAL
1		2	FIP X SOLDER X FIP TEE	LEAD FREE BRASS ALLOY ASTM B584 C89833/C87850
2		1	TIE BAR SUB ASSEMBLY	HARD COPPER TUBING UNS C12200 H80 TEMPER
3	330HI5428N	1	1" MIP X 1" CTS COMPRESSION TAILPIECE	LEAD FREE BRASS ALLOY ASTM B584 C89833/C87850
4	B242860IN	1	FULL PORT BALL VALVE	LEAD FREE BRASS ALLOY ASTM B584 C89833/C87850
5	HI4204N	1	METER COUPLING	LEAD FREE BRASS ALLOY ASTM B584 C89833/C87850
6		2	RISER SUB ASSEMBLY	HARD COPPER TUBING UNS C12200 H80 TEMPER

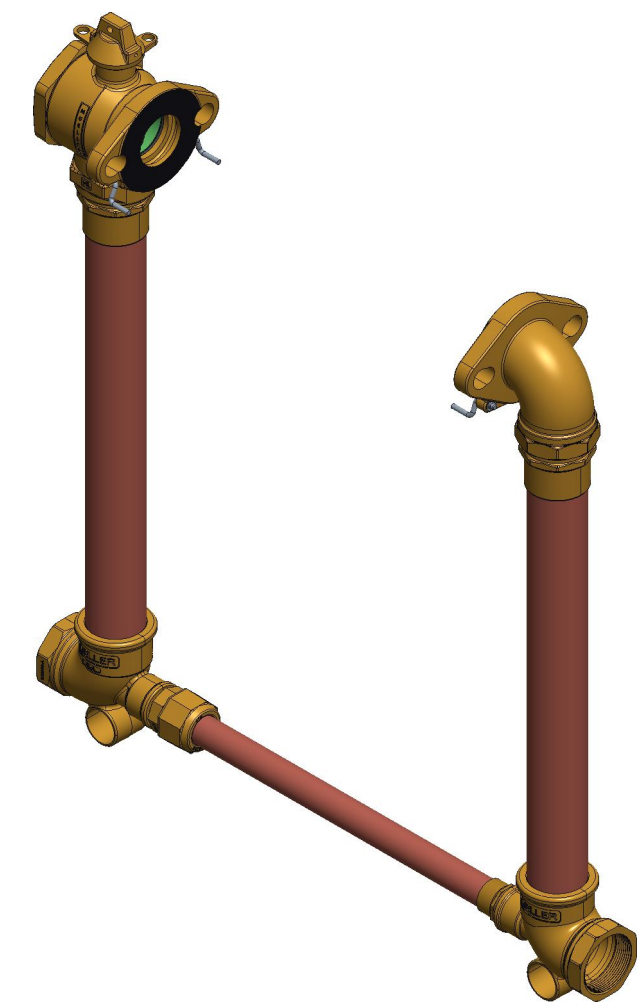
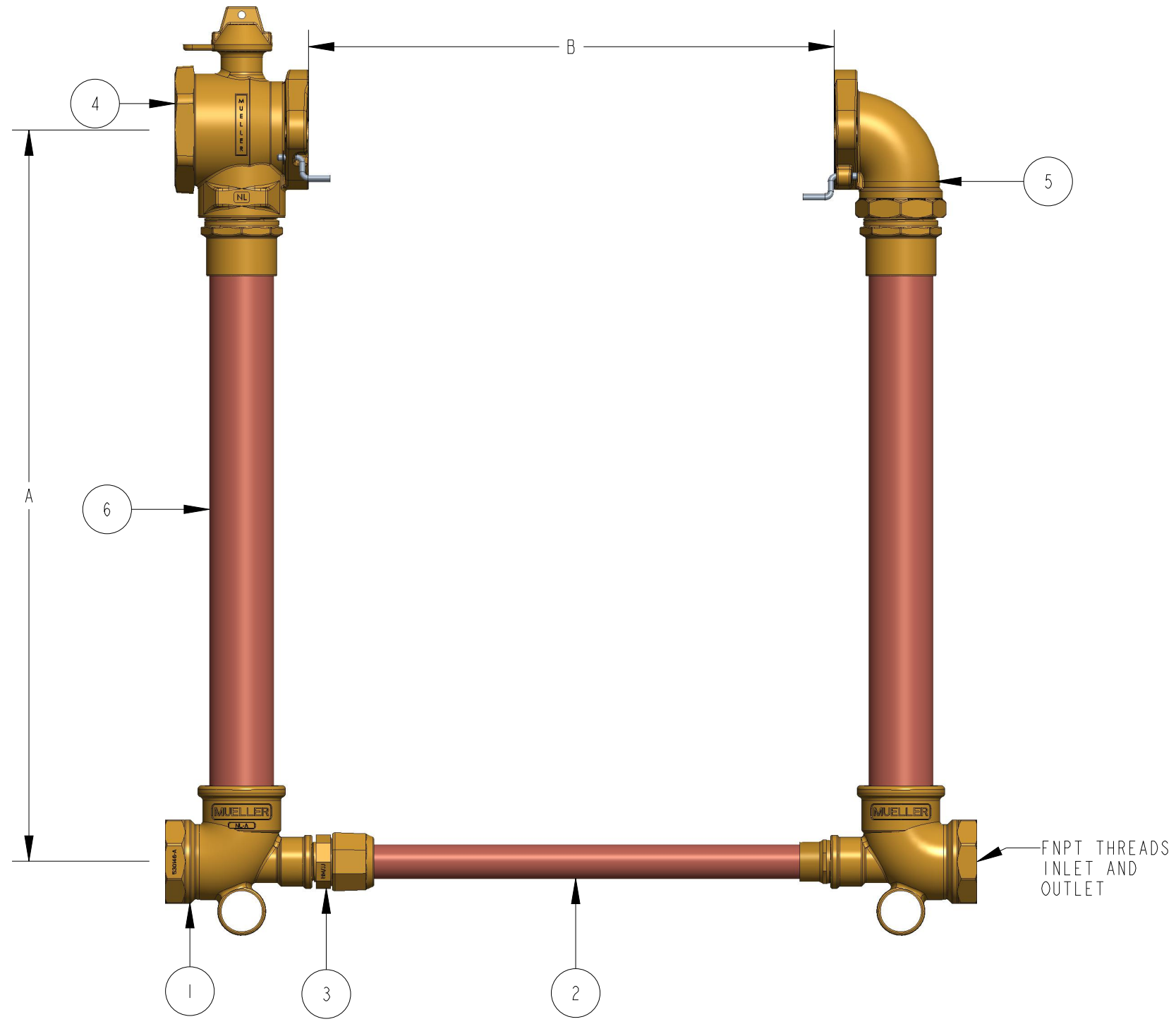

B2422-----N

DR. BY	AOD	3/02/23	UNLESS OTHERWISE NOTED	THIRD ANGLE PROJECTION	C.B. NO.
CHKR			BREAK CAST CORNER(S)---		
ENGR			BREAK MACH CORNER(S)---	PURCH.	FINISH
MGR			TOLERANCES	REF. NO.	PATT. NO.
MFG			UNLESS OTHERWISE NOTED	SCALE	NONE
TOOL			LINEAR	ANGULAR	
FDRY			±	±	STK. NO.
MAT'L:					
MUELLER		DESCR.	COPPER METER SETTER LEAD FREE BRASS	NUMBER	B2422-----N