

No.	DESCRIPTION	MATERIAL
1	STEM	LEAD FREE BRASS ALLOY ASTM B584/B371
2	O-RING	EPDM D2000
3	BALL	LEAD FREE BRASS ALLOY ASTM B584
4	GASKET - SEAL	EPDM D2000
5	BODY	LEAD FREE BRASS ALLOY ASTM B584
6	O-RING	EPDM D2000
7	END PIECE	LEAD FREE BRASS ALLOY ASTM B584
8	COPPER GASKET	COPPER SHEET ASTM B152 UNS C11000
9	INSTA-TITE BODY	LEAD FREE BRASS ALLOY ASTM B584
10	O-RING	EPDM D2000
11	GRIP RING	CELCON M90 NATURAL CF2001
12	CAP	CAST BRASS ALLOY ASTM B584
13	COTTER PIN	STAINLESS STEEL
14	SILICON CAP	SILICON RUBBER

SIZE	ØA	B	C	D	E
3/4"	.75	3.95	.84	2.12	2.96
1"	1.00	4.87	1.15	2.30	3.45

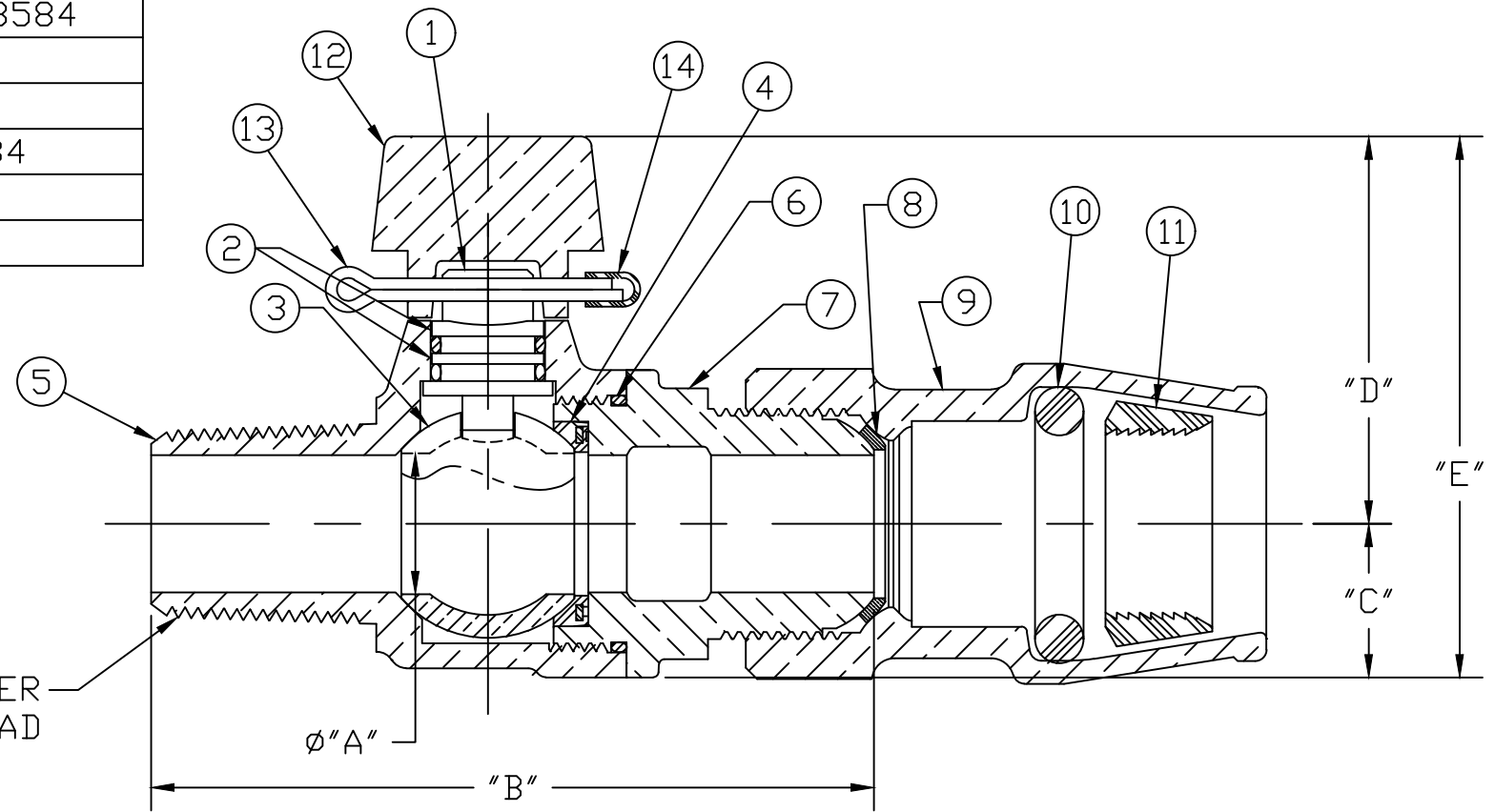

MUELLER  
"AWWA IP" THREAD

MEETS ALL REQUIREMENTS OF AWWA C800  
 ALL STEMS ARE LEAD FREE BRASS ALLOY C89833/C69300  
 ALL WETTED PARTS ARE LEAD FREE BRASS ALLOY C89833/C87850  
 ALL NON WETTED PARTS ARE BRASS ALLOY C83600/C87850

DWG NUMBER  
B2502600N

DRFTR	AD	03/08/23	<b>MUELLER</b>	
CHKR				
ENGR			UNLESS OTHERWISE NOTED SURFACE PREPARATION: BREAK CORNER(S) ---- .000 SURFACE FINISH -- XX RMS	THIRD ANGLE PROJECTION
MGR				REF. No.
	BY	DATE	LINEAR ----- ± .000	NONE
			ANGULAR ----- ± 0°00'	
STK No:				
MAT'L:				
DESCR.			BALL CORPORATION VALVE W/ DETACHABLE T-HEAD CAP ("AWWA IP" x IPS PE)	
			DWG NUMBER B2502600N	

TITLE TO AND OWNERSHIP OF THIS ENGINEERING  
 DATA REMAINS IN Mueller Co. NO USE IS TO BE  
 MADE OF THIS DATA EXCEPT AS SPECIFICALLY  
 AUTHORIZED BY Mueller Co. ASSENT ON THE PART  
 OF THE RECIPIENT TO THESE CONDITIONS IS PRESUMED